

**Dalton Gardens City Council Special Meeting
Tuesday, June 30, 2020 @ 5:00 PM**

Meeting will be conducted via teleconference, please use this link to join the webinar:

<https://us02web.zoom.us/j/84648840315?pwd=c3hna0hvY0YxTHhtRmpOO2lCNzZ3dz09>
Password: 581873

Or iPhone one-tap:

US: +12532158782,,84648840315#,,,,0#,,581873# or +13462487799,,84648840315#,,,,0#,,581873#

Or Telephone: Dial (for higher quality, dial a number based on your current location):

US: +1 253 215 8782 or +1 346 248 7799 or +1 669 900 6833

Webinar ID: 846 4884 0315, Password: 581873

CALL MEETING TO ORDER

ROLL CALL:

PUBLIC COMMENT

Each speaker will be allowed a maximum of three minutes to address the City Council on matters that relate to City government business. Comments related to future public hearings should be held for that public hearing. Please be advised that the City Council can only take official action this evening for those items already listed on the agenda.

1. ACTION ITEM – APPROVAL TO AMEND TITLE 2 – BOARDS AND COMMISSIONS, TO ADD A NEW CHAPTER 3 – FINANCE COMMISSION, TO DALTON GARDENS CITY CODE – ORDINANCE 266

2. ACTION ITEM – APPROVAL TO AMEND TITLE 2 – BOARDS AND COMMISSIONS TO ADD A NEW CHAPTER 4 – TRAFFIC COMMISSION, TO DALTON GARDENS CITY CODE - ORDINANCE 267

3. ACTION ITEM – APPROVAL OF AMENDING TITLE 9, CHAPTER 1, SECTION 1 OF DALTON GARDENS MUNICIPAL CODE TO CLARIFY REQUIREMENTS FOR APPROACHES TO PRIVATE PROPERTY – ORDINANCE 268

4. ACTION ITEM – DISCUSSION REGARDING REQUEST FROM ISAAC REINHERT FOR AN ALTERED TURNAROUND ON 18TH STREET

5. ACTION ITEM – APPOINTMENT OF DREW DITTMAN TO PLANNING & ZONING COMMISSION

6. ACTION ITEM – APPROVAL OF 2020 ASPHALT REPAIR AGREEMENT WITH ROCK PRODUCTS INC.

7. ACTION ITEM – DISCUSSION OF LAKE CITY LAW AS CITY ATTORNEY EFFECTIVE JULY 1.

ACTION ITEM - ADJOURN

ORDINANCE NO 266

AN ORDINANCE OF THE CITY OF DALTON GARDENS, A MUNICIPAL CORPORATION OF THE STATE OF IDAHO, AMENDING TITLE 2 – BOARDS AND COMMISSIONS, TO ADD A NEW CHAPTER 3 – FINANCE COMMISSION, TO DALTON GARDENS CITY CODE, ESTABLISHING AND DEFINING THE COMMISSION; PROVIDING FOR SEVERABILITY; PROVIDING REPEAL OF CONFLICTING ORDINANCES; AND PROVIDING AN EFFECTIVE DATE.

BE IT ORDAINED by the Mayor and City Council of the city of Dalton Gardens, Kootenai County, Idaho, as follows:

Section 1. Dalton Gardens City Code Title 2 – Boards and Commissions, shall be, and the same is, amended to add a new Chapter 3 – Finance Commission, as follows:

2-3-1: ESTABLISHMENT:

Based upon the provisions delineated in Idaho Code 50-210 and all subsequent and amended sections, the Dalton Gardens city council establishes and creates a commission to be known as the Dalton Finance Commission

- A. There is hereby established a Finance Commission (hereinafter “Commission”) in the city of Dalton Gardens, which shall consist of no fewer than five (5) and no more than nine (9) members. Members shall be appointed by the mayor and confirmed by the city council. Members shall serve at the pleasure of the governing board and may be removed upon a majority vote of the city council. Members shall be residents of the city of Dalton Gardens.
- B. A majority of the then appointed membership of the Commission shall constitute a quorum for the transaction of business.

2-3-2: TERM OF OFFICE; VACANCIES:

The terms of office for the first appointive members shall be three (3) years, or until a successor is appointed and qualified. Terms shall expire on December 31 of the last year of the designated term. No person shall serve more than two (2) full consecutive terms without specific concurrence by two-thirds ($\frac{2}{3}$) of the governing board adopted by motion and recorded in the minutes. Vacancies on the Commission occurring other than by expiration of the term shall be filled by the mayor with the consent of the city council for the remainder of the unexpired term.

2-3-3: COMMISSION ORGANIZATION AND RECORDKEEPING:

The mayor shall appoint one member as the chairperson of the Commission and the members shall select a secretary who will create and maintain records for the Commission.

2-3-4: DUTIES AND RESPONSIBILITIES:

- A. The Commission shall not be deemed to be other than an advisory committee to advise and assist the mayor and city council.
- B. The Commission shall perform its activities as directed by the mayor and city council.
- C. The Commission is intended to enhance communication between the mayor, city council and city staff of significant items affecting public policy questions as it relates to the commission.
- D. The Commission shall develop and maintain a level of knowledge on matters which might affect public policy in order to increase the positive exchange of information and discussions between the mayor, city council, city staff, and the public.
- E. The Commission shall submit a written activity report to the city clerk for inclusion in the city council packet seven (7) days prior to the regularly scheduled council meeting.

2-3-5: MEETINGS AND ATTENDANCE:

- A. The Commission shall meet at a regular place and time as determined by resolution of the commission. All meetings of the Commission shall follow the requirements of Idaho's open meeting laws to allow and promote public participation in the subject matter considered by the Commission. The Commission shall keep minutes and other appropriate written records of its resolutions, proceedings, and actions, which shall be kept as a public record. The Commission will give monthly updates to the mayor and the city council, when appropriate.
- B. The Commission shall attend their appointed and confirmed positions at such Commission meetings. Any appointed member of the Commission may be removed for cause by the mayor upon a majority vote of the city council. Any Commission member who is absent from any series of three (3) consecutive regular meetings, or who fails to attend at least seventy five percent (75%) of such regular meetings in a calendar year, shall be deemed to have resigned from the Commission and the mayor and city council will be notified of the vacancy. The appointed person shall no longer serve on the Commission and the seat/position shall be deemed vacant. The vacancy of such position shall be appointed and confirmed as provided by state law and Dalton City Code.

Section 2. This ordinance is hereby declared to be severable. Should any portion of this ordinance be declared invalid by a court of competent jurisdiction, the remaining provisions shall continue in full force and effect and shall be read to carry out the purpose(s) of the ordinance before the declaration of partial invalidity.

Section 3. All provisions of the current Dalton Gardens Municipal Code, or ordinances of the city of Dalton Gardens, which conflict with the provisions of this ordinance are hereby repealed to the extent of such conflict.

Section 4. This Ordinance shall be in full force and effect from and after its passage, approval, and publication according to law.

PASSED by the City Council as an Ordinance of the city of Dalton Gardens upon roll call vote on the ____ day of _____, 2020.

APPROVED by the Mayor on this ____ day of _____, 2020.

CITY OF DALTON GARDENS, IDAHO

By: _____
Dan Edwards, Mayor

ATTEST:

Valerie Anderson, City Clerk

ORDINANCE NO 267

AN ORDINANCE OF THE CITY OF DALTON GARDENS, A MUNICIPAL CORPORATION OF THE STATE OF IDAHO, AMENDING TITLE 2 – BOARDS AND COMMISSIONS, TO ADD A NEW CHAPTER 4 – TRAFFIC COMMISSION, TO DALTON GARDENS CITY CODE, ESTABLISHING AND DEFINING THE COMMISSION; PROVIDING FOR SEVERABILITY; PROVIDING REPEAL OF CONFLICTING ORDINANCES; AND PROVIDING AN EFFECTIVE DATE.

BE IT ORDAINED by the Mayor and City Council of the city of Dalton Gardens, Kootenai County, Idaho, as follows:

Section 1. Dalton Gardens City Code Title 2 – Boards and Commissions, shall be, and the same is, amended to add a new Chapter 4 – Traffic Commission, as follows:

2-3-1: ESTABLISHMENT:

Based upon the provisions delineated in Idaho Code 50-210 and all subsequent and amended sections, the Dalton Gardens city council establishes and creates a commission to be known as the Dalton Traffic Commission.

- A. There is hereby established a Traffic Commission (hereinafter “Commission”) in the city of Dalton Gardens, which shall consist of no fewer than five (5) and no more than nine (9) members. Members shall be appointed by the mayor and confirmed by the city council. Members shall serve at the pleasure of the governing board and may be removed upon a majority vote of the city council. Members shall be residents of the city of Dalton Gardens.
- B. A majority of the then appointed membership of the Commission shall constitute a quorum for the transaction of business.

2-3-2: TERM OF OFFICE; VACANCIES:

The terms of office for the first appointive members shall be three (3) years, or until a successor is appointed and qualified. Terms shall expire on December 31 of the last year of the designated term. No person shall serve more than two (2) full consecutive terms without specific concurrence by two-thirds ($\frac{2}{3}$) of the governing board adopted by motion and recorded in the minutes. Vacancies on the Commission occurring other than by expiration of the term shall be filled by the mayor with the consent of the city council for the remainder of the unexpired term.

2-3-3: COMMISSION ORGANIZATION AND RECORDKEEPING:

The mayor shall appoint one member as the chairperson of the Commission and the members shall select a secretary who will create and maintain records for the Commission.

2-3-4: DUTIES AND RESPONSIBILITIES:

- A. The Commission shall not be deemed to be other than an advisory committee to advise and assist the mayor and city council.
- B. The Commission shall perform its activities as directed by the mayor and city council.
- C. The Commission is intended to enhance communication between the mayor, city council and city staff of significant items affecting public policy questions as it relates to the Commission.
- D. The Commission shall develop and maintain a level of knowledge on matters which might affect public policy in order to increase the positive exchange of information and discussions between the mayor, city council, city staff, and the public.
- E. The Commission shall submit a written activity report to the city clerk for inclusion in the city council packet seven (7) days prior to the regularly scheduled council meeting.

2-3-5: MEETINGS AND ATTENDANCE:

- A. The Commission shall meet at a regular place and time as determined by resolution of the commission. All meetings of the Commission shall follow the requirements of Idaho's open meeting laws to allow and promote public participation in the subject matter considered by the Commission. The Commission shall keep minutes and other appropriate written records of its resolutions, proceedings, and actions, which shall be kept as a public record. The Commission will give monthly updates to the mayor and the city council, when appropriate.
- B. The Commission shall attend their appointed and confirmed positions at such Commission meetings. Any appointed member of the Commission may be removed for cause by the mayor upon a majority vote of the city council. Any Commission member who is absent from any series of three (3) consecutive regular meetings, or who fails to attend at least seventy five percent (75%) of such regular meetings in a calendar year, shall be deemed to have resigned from the Commission and the mayor and city council will be notified of the vacancy. The appointed person shall no longer serve on the Commission and the seat/position shall be deemed vacant. The vacancy of such position shall be appointed and confirmed as provided by state law and Dalton City Code.

Section 2. This ordinance is hereby declared to be severable. Should any portion of this ordinance be declared invalid by a court of competent jurisdiction, the remaining provisions shall continue in full force and effect and shall be read to carry out the purpose(s) of the ordinance before the declaration of partial invalidity.

Section 3. All provisions of the current Dalton Gardens Municipal Code, or ordinances of the city of Dalton Gardens, which conflict with the provisions of this ordinance are hereby repealed to the extent of such conflict.

Section 4. This Ordinance shall be in full force and effect from and after its passage, approval, and publication according to law.

PASSED by the City Council as an Ordinance of the city of Dalton Gardens upon roll call vote on the ____ day of _____, 2020.

APPROVED by the Mayor on this ____ day of _____, 2020.

CITY OF DALTON GARDENS, IDAHO

By: _____
Dan Edwards, Mayor

ATTEST:

Valerie Anderson, City Clerk

ORDINANCE NO 268

AN ORDINANCE OF THE CITY OF DALTON GARDENS, A MUNICIPAL CORPORATION OF THE STATE OF IDAHO, AMENDING TITLE 9, CHAPTER 1, SECTION 1 OF DALTON GARDENS MUNICIPAL CODE TO CLARIFY REQUIREMENTS FOR APPROACHES TO PRIVATE PROPERTY; PROVIDING FOR SEVERABILITY; PROVIDING REPEAL OF CONFLICTING ORDINANCES; AND PROVIDING AN EFFECTIVE DATE.

BE IT ORDAINED by the Mayor and City Council of the city of Dalton Gardens, Kootenai County, Idaho, that Title 9, Chapter 1, Section 1: Access from Private Property to Public Ways and Private Streets; Approach is hereby amended as follows:

Section 1. Dalton Gardens Municipal Code Title 9, Chapter 1, Section 9-1-1 is hereby amended as follows:

9-1-1: ACCESS FROM PRIVATE PROPERTY TO PUBLIC WAYS AND PRIVATE STREETS; APPROACH:

A. Definitions:

APPROACH: A point of vehicular access from private property onto a public right-of-way.

DRIVEWAY, COMMERCIAL: A means of vehicular access from private property that is zoned commercial or a business that carries an active business license within the City that services one or more lots or parcels onto a public or private road or street.

DRIVEWAY, COMMON: A means of vehicular access from private property that serves two (2) or more lots or parcels onto a public or private road or street.

DRIVEWAY, RESIDENTIAL, COMMUNITY OR PUBLIC: A means of vehicular access from private residential, community (schools, community centers or churches) or public (property owned by the government) property onto a public or private road or street to a point within an individual lot.

PUBLIC RIGHT-OF-WAY: A right-of-way open to the public and under the jurisdiction of a public agency, where the public agency has no obligation to construct or maintain said right-of-way for vehicular traffic, nor shall there be any liability for any injury or damage for failure to maintain it or any highway signs.

RIGHT-OF-WAY: A parcel of land dedicated or reserved for use as a public way, which normally includes streets, sidewalks, utilities or other service functions.

B. Permit Required:

1. All vehicular approaches (private, common, commercial or public driveways) shall obtain ~~require~~ an approach permit prior to construction of the approach.

2. A single approach for ~~one single family dwelling~~ a residential parcel is exempt from the requirement for a separate approach permit, when shown on the site plan and submitted as part of a building permit for a primary structure. All the requirements of the approach standards shall continue to apply. ~~The number of approaches serving an individual lot or parcel may be restricted to a single two-way approach, and in some cases, common driveways serving two (2) or more lots may be required. The width of an approach shall be determined according to this Code and shall meet the requirements of the local fire protection district.~~

3. ~~The City Council may approve annual approach permit agreements with utility companies having existing franchise agreements with the City or regulated by the Idaho Public Utilities Commission.~~

C. Permit Application: No approach permit under this chapter shall be issued unless a written application for the issuance of an approach permit is submitted to the City. The application shall be reviewed by the City. Prior to permit issuance, the applicant shall stake mark the driveway location for a site inspection by the City. ~~The City, per the Local Highway Technical Assistance Council's "Manual for Use of Public Right of Way, Standard Approach Policy" has the right to~~ may require a traffic study studies to determine impacts and applicable mitigation to of impacts. The City Clerk shall issue the permit only after all application items have been completed or satisfactorily addressed, all reviews have been completed and all fees have been paid.

D. Approach Standards:

1. The number of approaches serving an individual lot or parcel may be restricted to a single two-way approach, and in some cases, common driveways serving two or more lots may be required. No residential parcel located outside of the incorporated city limits of Dalton Gardens shall be eligible for a second approach onto a right of way owned by the city of Dalton Gardens. ~~All vehicular approaches shall be located, designed and constructed according to this code, as amended, and the local highway technical assistance council's "Manual For Use Of Public Right-Of-Way, Standard Approach Policy", as amended and adopted by reference to the extent it is not in conflict with this code, with the exception of application fees as set forth in section F of said manual.~~

2. ~~The width of a single private driveway approach shall be determined according to this code a~~ minimum of 14 feet and a maximum of 24 feet, and shall meet the requirements of the local fire protection district. At a minimum, the width of the private driveway shall be twenty feet (20') with a driving surface of twelve feet (12') for residential properties.

3. ~~Common residential driveways or approaches that access two (2) or more lots or parcels, commercial accesses and other off street parking areas shall~~ have a minimum width of 20 feet, and a maximum width of 28 feet. be laid out and designed according to the local highway technical assistance council's "Manual For Use Of Public Right Of Way, Standard Approach Policy", as amended and adopted by reference to the extent it is not in conflict with this code, with the exception of application fees as set forth in section F of said manual and meet the following additional requirements:

a. ~~Approach Widths: The minimum driveway and approach widths shall be determined from the operating speed and the classification of the street providing access, the volume of traffic being generated, the potential for truck use, and fire protection requirements. The maximum two-way approach and driveway width shall be forty feet (40') where it can be demonstrated that~~

~~generated traffic warrants a separate left turn lane for exiting vehicles. A forty foot (40') wide approach may also be considered where heavy truck use prevails.~~

~~b. Pavement Markings: Pavement markings for persons with disabilities, pathways, crosswalks, stop bars, delineations, turning arrows, bicycles, etc., may be required.~~

4. Except in cases where an approach is shared with an adjacent parcel, approaches shall not be located closer than five (5) feet to the side property line, and when a parcel is granted a second approach on the same property, the approaches shall be separated by a minimum of thirty (30) feet.

~~E. Permit Fees: An approach permit fee based on the application shall be charged by the city for issuance of an approach permit under this chapter and to pay for the cost of inspection of the work by the city, according to a schedule of charges to be adopted by resolution and policy of the city council. Fees for an approach permit and inspections related to such permits shall as set forth in the duly adopted fee resolution for the City.~~

Section 2. Severability. This ordinance is hereby declared to be severable. Should any portion of this ordinance be declared invalid by a court of competent jurisdiction, the remaining provisions shall continue in full force and effect and shall be read to carry out the purpose(s) of the ordinance before the declaration of partial invalidity.

Section 3. Repeal of Conflicting Provisions. All provisions of the current Dalton Gardens Municipal Code, or ordinances of the city of Dalton Gardens, which conflict with the provisions of this ordinance are hereby repealed to the extent of such conflict.

Section 4. Effective Date. This Ordinance shall be in full force and effect from and after its passage, approval, and publication according to law.

PASSED by the City Council as an Ordinance of the city of Dalton Gardens upon roll call vote on the ___ day of June, 2020.

APPROVED by the Mayor on this ___ day of June, 2020.

CITY OF DALTON GARDENS, IDAHO

By: _____
Dan Edwards, Mayor

ATTEST:

Valerie Anderson, City Clerk



City of Dalton Gardens

6360 N Fourth Street, Dalton Gardens, ID 83815

Phone: (208) 772-3698 Fax: (208) 762-5156

MEMORANDUM

TO: Mayor and City Council

FROM: Rand Wichman, City Planner

DATE: June 22, 2020

RE: AMENDMENTS TO MUNICIPAL CODE REGARDING DRIVEWAY
APPROACHES – ORDINANCE #268

Background

After a recent inquiry regarding an existing unpermitted approach on the south side of Dalton Avenue, I reviewed the City's policy, or lack thereof, regarding approaches onto the Dalton Ave. from properties located in the City of Coeur d'Alene. With input from the City Attorney and Mayor, we decided the best approach was to memorialize the appropriate policy into the Municipal Code. While we are amending the code to address this issue on approaches to Dalton, I have also recommended additional changes to this section to address other issues that we have struggled with in the past. This draft represents my recommended amendments.

Discussion of Changes

Some of the proposed amendments are simple changes to make the language clearer or more precise. The amendments also relocate standards to the appropriate section, and remove extraneous language (e.g. Section 9-1-1 B.2 and B.3).

The existing code has historically used the Local Highway Technical Assistance Council's "Manual for Use of Public Right of Way" for guidance on when to require a traffic study and for standards related to approaches. This document is not well-suited to use in the unique road environment that exists in Dalton Gardens, so I have recommended removal of that manual as a reference. The standards that the City needs to regulate approaches are now incorporated directly into the Code.

Correction

Section 9-1-1 E. has a typo and should be amended to include the word “be” as follows: “Fees for an approach permit and inspections related to such permits shall **be** as set forth in the duly adopted fee resolution for the City.”

Because I will not be in attendance at the Council meeting on the 25th, please feel free to contact me before the end of the day on Wednesday, June 24th if you have any questions.



City of Dalton Gardens

6360 N Fourth Street, Dalton Gardens, ID 83815

Phone: (208) 772-3698 Fax: (208) 762-5156

MEMORANDUM

TO: Mayor and City Council

FROM: Rand Wichman, City Planner

DATE: June 22, 2020

RE: PROPOSAL FOR ALTERNATE TURNAROUND ON 18TH STREET

Background

Last summer, the City Council reviewed a request from a property owner to abandon the temporary culdesac at the end of the publicly-maintained section of 18th Street. After receiving input from the Fire District on the need to maintain the turnaround, the Council decided not to abandon the easement.

The current property owner, Isaac Reinert, has contacted staff several times over the last several months to discuss options for removal of this turnaround. Mr. Reinert has started the process of building a new driveway approach in this area to access a new accessory building. This presents an opportunity to replace the existing turnaround.

Turnaround Requirements

A temporary culdesac was required as part of the platting of Canfield Meadows First Addition subdivision in 1994. The thinking at the time was that 18th Street would eventually be extended down to Dalton Avenue and that would eliminate the need for a culdesac on this street.

The portion of the culdesac that is on what is now Mr. Reinert's property was constructed by the developer, but the portion of the culdesac on the east side of 18th was never constructed. As a result, the current configuration has a driving surface with a maximum diameter of approximately 60 feet. As depicted on the diagram below, a typical fire-code standard culdesac has a diameter of 96 feet.

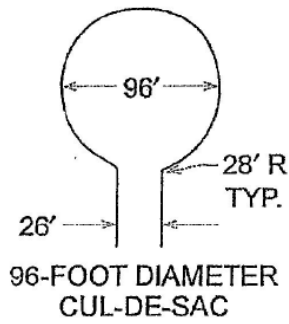

Mr. Reinert proposes to replace the existing sub-standard culdesac with a full-standard alternative hammerhead type turnaround. This turnaround would look like the following diagram, with the north-south axis being 18th Street and the 70' dimension being his new approach to his accessory building.

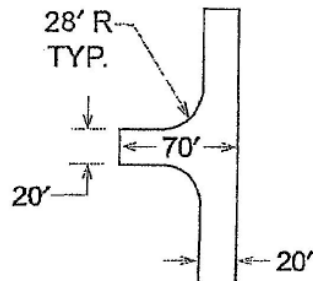

The south edge of the turnaround would be located south of the existing culdesac, approximately 5 feet north of Mr. Reinert's property line, as roughly depicted in light blue in the aerial below.

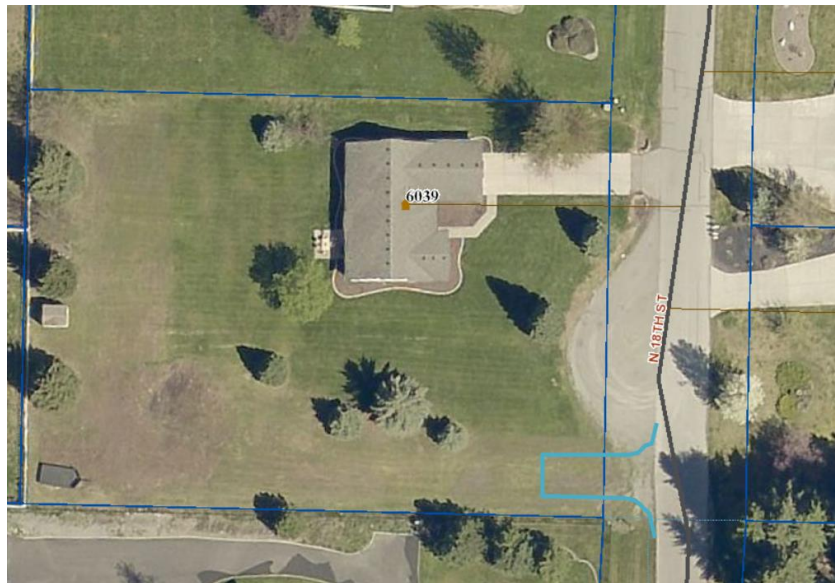

Review and Recommendations

Staff has discussed this concept with the Fire District and they have indicated that they would support this approach. Staff agrees with the Fire District that a fully compliant alternative hammerhead is preferable to a substandard culdesac. It would also be beneficial to the property owner, significantly reducing the size of the encroachment on his property.

A new, temporary easement from Mr. Reinert would be needed to allow for public use of the portion of the new turnaround that falls within his lot. That easement would be drafted by the City Attorney. Once the turnaround is constructed and the easement is executed, the City would relinquish the easement for the temporary culdesac. Mr. Reinert would then remove the culdesac and landscape the area. The alternative hammerhead and the accompanying easement would stay in place until a new turnaround could be constructed farther south on 18th, or the road was constructed down to Dalton Ave.

This matter is before the City Council for conceptual approval, prior to construction or drafting of the necessary easement documents. If the Council is in favor, the matter will come back to the Council at a future meeting for formal acceptance of the easement and vacation of the existing easement.

Because I will not be in attendance at the Council meeting on the 25th, please feel free to contact me before the end of the day on Wednesday, June 24th if you have any questions.

Proposed option for 18th Street turn-around

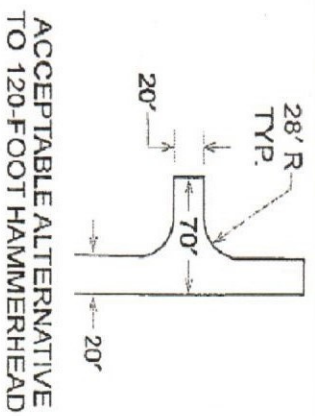
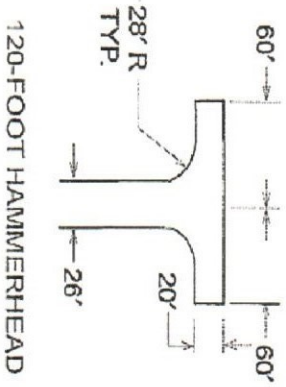
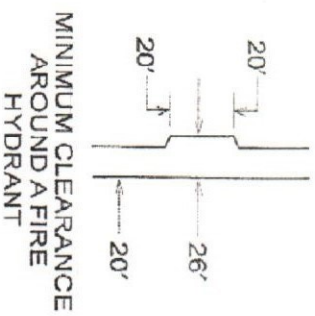
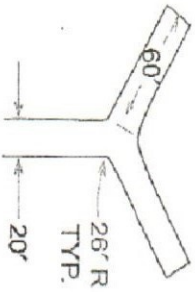
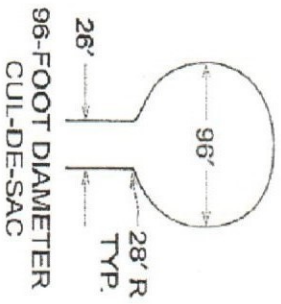



City of Dalton Gardens

From: Caitlin Kling <CKling@hawleytroxell.com>
Sent: Friday, May 29, 2020 10:44 AM
To: 'City of Dalton Gardens'
Cc: 'Rand Wichman'
Subject: Additional agenda item [IWOV-IMANAGE.FID1063338]

Hi Valerie,

Rand and I have one more item for the agenda for June 4th. Please add: "Action Item: Discussion regarding request from Isaac Reinert for an altered turnaround on 18th Street"

Thanks,

CAITLIN D. KLING
Attorney
direct 208.667.1390 x4107
fax 208.954.5263
email ckling@hawleytroxell.com

HAWLEY TROXELL

Attorneys and Counselors at Law



Member

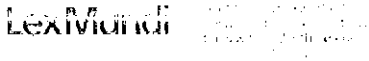

This e-mail message from the law firm of Hawley Troxell Ennis & Hawley, LLP is intended only for named recipients. It contains information that may be confidential, privileged, attorney work product, or otherwise exempt from disclosure under applicable law. If you have received this message in error, are not a named recipient, or are not the employee or agent responsible for delivering this message to a named recipient, be advised that any review, disclosure, use, dissemination, distribution, or reproduction of this message or its contents is strictly prohibited. Please notify us immediately at 208.344.6000 if you have received this message in error, and delete the message.



Please consider the environment before printing this email.



City of Dalton Gardens

CERTIFICATE OF APPOINTMENT

KNOW ALL MEN BY THESE PRESENTS:

That I, Dan Edwards, Mayor of the City of Dalton Gardens, County of Kootenai,

State of Idaho, have appointed:

DREW DITTMAN

As Planning & Zoning Commissioner in and for the City of Dalton Gardens, State of Idaho,

Effective July 1, 2020. This appointment will be good until July 2023

unless otherwise revoked in writing.

Dan Edwards, Mayor, City of Dalton Gardens, Idaho

**AGREEMENT
2020 Asphalt Repair Project**

This AGREEMENT (“Agreement”) is made and entered into this 25th day of June, 2020 (“Effective Date”), by and between the City of Dalton Gardens, a political subdivision of the state of Idaho, 6360 N. Fourth Street, Dalton Gardens, ID (hereinafter “CITY”) and RPI Road Products, Inc., P.O. Box 11072, Spokane, WA 99211 (hereinafter “CONTRACTOR”). CITY and CONTRACTOR may collectively be referred to as the “parties” and individually as a “party.”

THE PARTIES AGREE AS FOLLOWS:

1. SCOPE OF WORK: CITY hereby employs CONTRACTOR as an independent contractor to complete and perform the following project:

Asphalt patching and traffic control Prairie Avenue; asphalt patching, asphalt overlay and traffic control on Deerhaven; and asphalt patching and traffic control on 4th Street, in accordance with the attached Plans and Specifications, attached hereto and incorporated herein by reference as **Exhibit “A.”**

The parties agree to coordinate with each other to facilitate a timely and professional process. Contact information is:

CITY:
Valerie Anderson, City Clerk
6360 N. Fourth Street
Dalton Gardens, ID

CONTRACTOR:
Road Products, In,
PO Box 11072
Spokane Valley, WA 99211

2. TIME OF PERFORMANCE: The parties agree that CONTRACTOR shall complete all identified work listed on the attached bid form on or before September 30, 2020, and that on or before that date all work shall be finished.

3. COMPENSATION: The CITY agrees to pay CONTRACTOR as compensation a sum of \$49,981.75 for the work described in **Exhibit “A”**; payable within sixty (60) days of completion of the project and acceptance by CITY.

4. INDEPENDENT CONTRACTOR: The parties agree that CONTRACTOR is an independent contractor of CITY and in no way an employee or agent of CITY and is not entitled to workers compensation or any benefit of employment with the CITY. The CITY shall have no control over the performance of this Agreement by CONTRACTOR or its employees, except to specify the time and place of performance, and the results to be achieved. The CITY shall have no responsibility for security or protection of CONTRACTOR'S supplies or equipment. CONTRACTOR agrees to pay and be responsible for all taxes due from the compensation received under this contract.

5. INDEMNIFICATION: CONTRACTOR agrees to indemnify, defend, and hold harmless CITY, and its officers, agents and employees, from and against any and all claims, losses, actions, or judgments for damages or injury to persons or property arising out of or in connection with the acts and/or any performances or activities of CONTRACTOR, CONTRACTOR's agents, employees, or representatives under this Agreement.

6. PERFORMANCE AND PAYMENT BONDS: At the time of contracting, CONTRACTOR has provided to CITY both a Performance Bond and a Payment bond each in the amount of 100% the project, attached hereto and incorporated herein by reference as **Exhibit "B"** and **Exhibit "C,"** respectively.

7. PUBLIC WORKS LICENSE: CONTRACTOR warrants that it has in effect an Idaho Public Works Contractor's License, License #PWC-C-12871-A-4 for the type and value of work to be performed under this Agreement. CONTRACTOR further warrants that CONTRACTOR will maintain said license in good standing with the State of Idaho during the entire term of the Agreement. Failure to maintain the license shall be considered a material breach and shall be grounds for termination of the Agreement by the CITY.

8. INSURANCE: CONTRACTOR agrees to obtain and keep in force during its acts under this Agreement a comprehensive general liability insurance policy in the minimum amount of \$1,000,000, which shall name and protect CONTRACTOR, all CONTRACTOR's employees, the CITY, and its officers, agents and employees, from and against any and all claims, losses, actions, and judgments for damages or injury to persons or property arising out of or in connection with the CONTRACTOR's acts. CONTRACTOR shall provide proof of liability coverage as set forth above to CITY prior to commencing its performance as herein provided, and require insurer to notify CITY ten (10) days prior to cancellation of said policy.

9. WORKER'S COMPENSATION: CONTRACTOR shall maintain in full force and effect worker's compensation for CONTRACTOR and any agents, employees, and staff that the CONTRACTOR may employ, and provide proof to CITY of such coverage or that such worker's compensation insurance is not required under the circumstances.

10. NON-DISCRIMINATION: CONTRACTOR shall not be discriminated against any person or entity in the providing of the services and/or materials herein under and CONTRACTOR shall not refuse to serve or hire any person because of such person's race, creed, sex, color, or national origin. Also, CONTRACTOR will in no manner discriminate against any person because of such person's race, creed, sex, color, or national origin. Any such discrimination shall be deemed a violation of this Agreement and shall render this Agreement subject to forfeiture.

11. COMPLIANCE WITH LAWS: CONTRACTOR agrees to comply with all federal, state, city, and local laws, rules and regulations.

12. SECTION HEADINGS: The section headings of this Agreement are for clarity in reading and not intended to limit or expand the contents of the respective sections to which they pertain.

13. ATTORNEY FEES AND COSTS: Should any litigation be commenced between the parties hereto concerning this Agreement, the prevailing party shall be entitled, in addition to any other relief as may be granted, to court cost and reasonable attorney fees as determined by a Court of competent jurisdiction. This provision shall be deemed to be a separate contract between the parties and shall survive any default, termination, or forfeiture of this Agreement.

14. ENTIRE AGREEMENT: This is the entire agreement of the parties and can only be modified or amended in writing by the parties.

15. NOTICES: All notices by either party to the other, required or provide for herein, shall be served by United States Postal Service, postage prepaid. If sent by mail, service of such notice shall be deemed complete when written notice is placed in the United States mail, postage pre-paid, addressed to the addresses listed above for the parties.

16. AUTHORITY: The parties hereto covenant and represent that the execution of this Agreement has been authorized by the governing Manager/Member/Council of the respective party, and the individual signatures set forth herein are authorized and binding upon the respective party.

IN WITNESS WHEREOF, the parties have executed this Agreement effective as of the Effective Date.

CITY
City of Dalton Gardens

CONTRACTOR

By: _____
Dan Edwards, Mayor

By: Denise M Lawless
Printed Name: Denise M. Lawless
Title: President

ATTEST:

Valerie Anderson, City Clerk

PERFORMANCE BOND

KNOW ALL MEN BY THESE PRESENTS; That

Road Products, Inc., 9915 E. Trent Avenue, Spokane, WA 99206

(Name and Address of Contractor)

a Corporation (Corp., Partnership, or Individual), hereinafter called PRINCIPAL and

Travelers Casualty and Surety Company of America, 835 N. Post Street, Suite 203, Spokane, WA 99201

(Name and Address of Surety)

hereinafter called SURETY, are held and firmly bound unto the City of Dalton Gardens, Kootenai County, State of Idaho, hereinafter called the OWNER, in the penal sum of Forty-Nine Nine Hundred Eighty-One and 75/100 dollars (\$ 49,981.75) in lawful money of the United States, for the payment of which sum well and truly to be made, we bind ourselves, successors, and assigns, jointly and severally, firmly by these presents.

THE CONDITION OF THIS OBLIGATION is such that whereas, the PRINCIPAL entered into a certain Contract with the OWNER, dated the 9th day of June, 2020, a copy of which is hereto attached and made a part hereof for 2020 Asphalt Repair PROJECT.

NOW THEREFORE, if the PRINCIPAL shall well, truly and faithfully perform its duties, all the undertakings, covenants, terms, conditions, and agreements of said Contract during the original term thereof, and any extensions thereof which may be granted by the OWNER, with or without notice to the SURETY and during the one year guarantee period, and if it shall satisfy all claims and demands incurred under such contract, and shall fully indemnify and save harmless the OWNER from all costs and damages which it may suffer by reason of failure to do so, and shall reimburse and repay the OWNER, all outlay and expense which the OWNER may incur in making good any default, then this obligation shall be void; otherwise to remain in full force and effect.

PROVIDED FURTHER, that the said SURETY, for value received hereby, stipulates and agrees that no change, extension of time, alteration or addition to the terms of the contract or to the WORK to be performed thereunder or the SPECIFICATIONS accompanying the same shall in any wise affect its obligation on this BOND, and it does hereby waive notice of any such change, extension of time, alteration or addition to the terms of the Contract or to the WORK or to the SPECIFICATIONS.

IN WITNESS WHEREOF, this instrument is executed in two (2) counterparts, each one of which shall be deemed an original, this the 9th day of June, 2020.

ATTEST:

[Handwritten Signature]

(PRINCIPAL Secretary)

Road Products, Inc.

(PRINCIPAL)

By: *[Handwritten Signature]*

Title: President

(SEAL)

[Handwritten Signature]

(Witness as to PRINCIPAL)

Address: 9915 E. TROUT AVE

SPOKANE VALLEY, WA 99206

Travelers Casualty and Surety Company of America

SURETY

[Handwritten Signature]

(Attorney in Fact) Travis Long

Address: 835 N. Post Street, Suite 203

Spokane, WA 99201

ATTEST:

[Handwritten Signature]

(Witness to Surety) Sarah Long

Address: 835 N. Post Street, Suite 203

Spokane, WA 99201

NOTE: Date of Bond must not be prior to date of Contract. If Contractor is a Partnership, all partners should execute Bond.

IMPORTANT: Surety companies executing BONDS must appear on the Treasury Department's most current list (Circular 570 as amended) and be authorized to transact business in the State of Idaho. The power of attorney for the individual signing on behalf of the SURETY must be attached in order for the bond to be valid.

LABOR AND MATERIALS PAYMENT BOND

KNOW ALL MEN BY THESE PRESENTS THAT, WHEREAS THE City of Dalton gardens hereinafter designated the OWNER, has, on June 9, 2020, awarded to Road Products, Inc., hereinafter designated as the PRINCIPAL, a Contract for the construction of 2020 Asphalt Repair Project and

WHEREAS said PRINCIPAL is required to furnish a bond in connection and with said Contract, providing that if said PRINCIPAL or any of its subcontractors shall fail to pay for any materials, provisions, or other supplies used in, upon, for, or about the performance of the work contracted to be done, or for any work or labor done thereon of any kind, the Surety of this bond will pay the same to the extent hereinafter set forth:

Travelers Casualty and Surety

NOW THEREFORE WE, the PRINCIPAL, and Company of America as Surety, are held and firmly bound unto the OWNER for the penal sum of Forty-Nine Nine Hundred Eighty-One and 75/100 (\$ 49,981.75) lawful money of the United States, for the payment of which sum well and truly to be made we bind ourselves, our heirs, executors, administrators and successors, jointly and severally, firmly by these presents.

THE CONDITION OF THIS OBLIGATION IS SUCH that, if said PRINCIPAL, its heirs, executors, administrators, successors, or assigns, shall fail to pay for materials, provisions, or other supplies used in, upon, for, or about the performance of the work contracted to be done, or for any work or labor done thereon of any kind, or for amount due the Unemployment Insurance Act with respect to such work or labor, and provide that persons, companies, or corporations so furnishing said materials, provisions, or other supplies, appliances, or power use in, upon, for, or about the performance of the work contracted to be executed or performed, or any person who performs work or labor upon the same, or any person who supplies both work and materials thereto, shall have complied with the provisions of said Government Code, then said Surety will pay the same in or to an amount not exceeding the amount herein-above set forth, and also pay in case suit is brought upon this, such reasonable attorney's fees to the OWNER as shall be fixed by the court.

This Bond shall inure to the benefit of any and all persons, companies, and corporations entitled to file claims under said Government Code, so as to give a right of action to them or their assigns in any suit brought upon this bond.

And the said Surety, for value received, hereby stipulates and agrees that no change, extension of time, alteration, or addition of the terms of the Contract or to the work to be performed thereunder or the specifications accompanying the same shall, in any way, affect its obligations of this Bond, and it does hereby waive notice of any change, extension of time, alteration, or addition to the terms of the Contract or to the work or to the specifications.

IN WITNESS WHEREOF, the above bounden parties have executed this instrument under their seals this 9th day of June, 2020, the name and corporate seal of each corporate party being hereto affixed and these presents duly signed by its undersigned representative, pursuant to authority of its governing body.

Road Products, Inc.

PRINCIPAL

James M. Hawless / President

SIGNATURE OF PRINCIPAL/TITLE

Travelers Casualty and Surety Company of America

SURETY

[Signature]

SIGNATURE OF SURETY

Travis Long, Attorney-in-Fact

TITLE OF SIGNATORY





**Travelers Casualty and Surety Company of America
Travelers Casualty and Surety Company
St. Paul Fire and Marine Insurance Company**

POWER OF ATTORNEY

KNOW ALL MEN BY THESE PRESENTS: That Travelers Casualty and Surety Company of America, Travelers Casualty and Surety Company, and St. Paul Fire and Marine Insurance Company are corporations duly organized under the laws of the State of Connecticut (herein collectively called the "Companies"), and that the Companies do hereby make, constitute and appoint **Travis Long** of **SPOKANE Washington** their true and lawful Attorney-in-Fact to sign, execute, seal and acknowledge any and all bonds, recognizances, conditional undertakings and other writings obligatory in the nature thereof on behalf of the Companies in their business of guaranteeing the fidelity of persons, guaranteeing the performance of contracts and executing or guaranteeing bonds and undertakings required or permitted in any actions or proceedings allowed by law.

IN WITNESS WHEREOF, the Companies have caused this instrument to be signed, and their corporate seals to be hereto affixed, this 17th day of January, 2019.



State of Connecticut

City of Hartford ss.

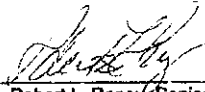
By: 
Robert L. Raney, Senior Vice President

On this the 17th day of January, 2019, before me personally appeared **Robert L. Raney**, who acknowledged himself to be the Senior Vice President of Travelers Casualty and Surety Company of America, Travelers Casualty and Surety Company, and St. Paul Fire and Marine Insurance Company, and that he, as such, being authorized so to do, executed the foregoing instrument for the purposes therein contained by signing on behalf of said Companies by himself as a duly authorized officer.

IN WITNESS WHEREOF, I hereunto set my hand and official seal.

My Commission expires the 30th day of June, 2021



Anna P. Nowik, Notary Public

This Power of Attorney is granted under and by the authority of the following resolutions adopted by the Boards of Directors of Travelers Casualty and Surety Company of America, Travelers Casualty and Surety Company, and St. Paul Fire and Marine Insurance Company, which resolutions are now in full force and effect, reading as follows:

RESOLVED, that the Chairman, the President, any Vice Chairman, any Executive Vice President, any Senior Vice President, any Vice President, any Second Vice President, the Treasurer, any Assistant Treasurer, the Corporate Secretary or any Assistant Secretary may appoint Attorneys-in-Fact and Agents to act for and on behalf of the Company and may give such appointee such authority as his or her certificate of authority may prescribe to sign with the Company's name and seal with the Company's seal bonds, recognizances, contracts of indemnity, and other writings obligatory in the nature of a bond, recognizance, or conditional undertaking, and any of said officers or the Board of Directors at any time may remove any such appointee and revoke the power given him or her; and it is

FURTHER RESOLVED, that the Chairman, the President, any Vice Chairman, any Executive Vice President, any Senior Vice President or any Vice President may delegate all or any part of the foregoing authority to one or more officers or employees of this Company, provided that each such delegation is in writing and a copy thereof is filed in the office of the Secretary; and it is

FURTHER RESOLVED, that any bond, recognizance, contract of indemnity, or writing obligatory in the nature of a bond, recognizance, or conditional undertaking shall be valid and binding upon the Company when (a) signed by the President, any Vice Chairman, any Executive Vice President, any Senior Vice President or any Vice President, any Second Vice President, the Treasurer, any Assistant Treasurer, the Corporate Secretary or any Assistant Secretary and duly attested and sealed with the Company's seal by a Secretary or Assistant Secretary; or (b) duly executed (under seal, if required) by one or more Attorneys-in-Fact and Agents pursuant to the power prescribed in his or her certificate or their certificates of authority or by one or more Company officers pursuant to a written delegation of authority; and it is

FURTHER RESOLVED, that the signature of each of the following officers: President, any Executive Vice President, any Senior Vice President, any Vice President, any Assistant Vice President, any Secretary, any Assistant Secretary, and the seal of the Company may be affixed by facsimile to any Power of Attorney or to any certificate relating thereto appointing Resident Vice Presidents, Resident Assistant Secretaries or Attorneys-in-Fact for purposes only of executing and attesting bonds and undertakings and other writings obligatory in the nature thereof, and any such Power of Attorney or certificate bearing such facsimile signature or facsimile seal shall be valid and binding upon the Company and any such power so executed and certified by such facsimile signature and facsimile seal shall be valid and binding on the Company in the future with respect to any bond or understanding to which it is attached.

I, **Kevin E. Hughes**, the undersigned, Assistant Secretary of Travelers Casualty and Surety Company of America, Travelers Casualty and Surety Company, and St. Paul Fire and Marine Insurance Company, do hereby certify that the above and foregoing is a true and correct copy of the Power of Attorney executed by said Companies, which remains in full force and effect.

Dated this 9th day of June, 2020



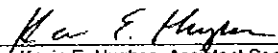

Kevin E. Hughes, Assistant Secretary

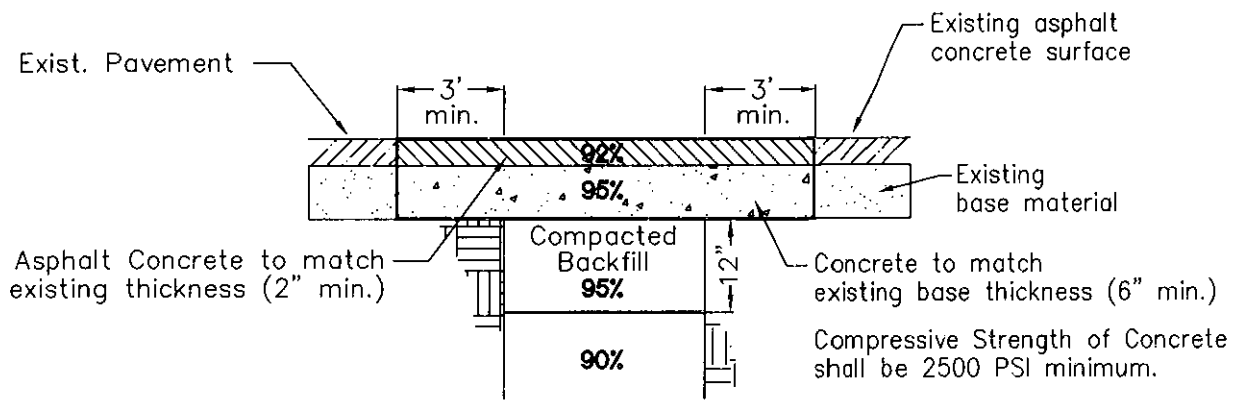
**To verify the authenticity of this Power of Attorney, please call us at 1-800-421-3880.
Please refer to the above-named Attorney-in-Fact and the details of the bond to which this Power of Attorney is attached.**

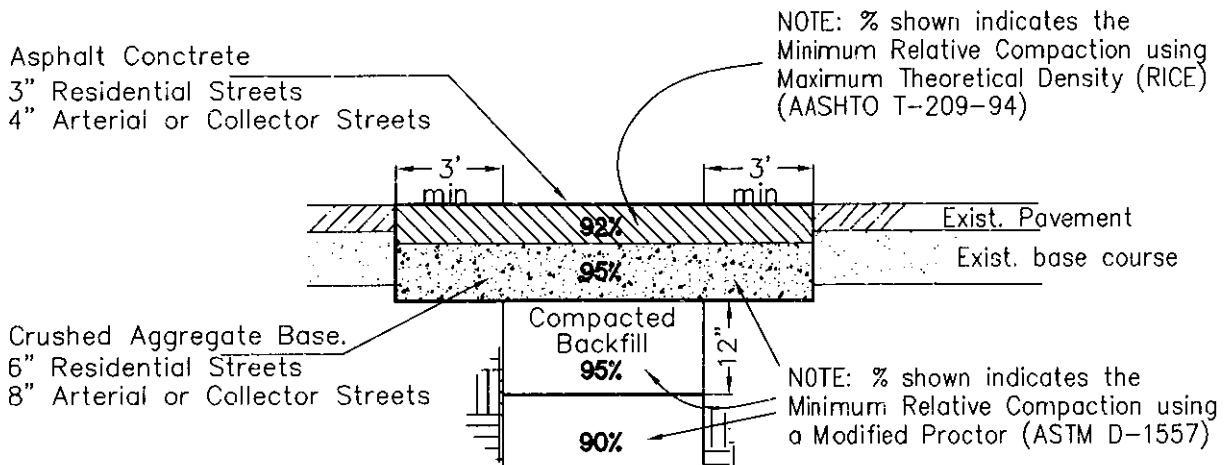

Type 'A' Repair



Type 'B' Repair

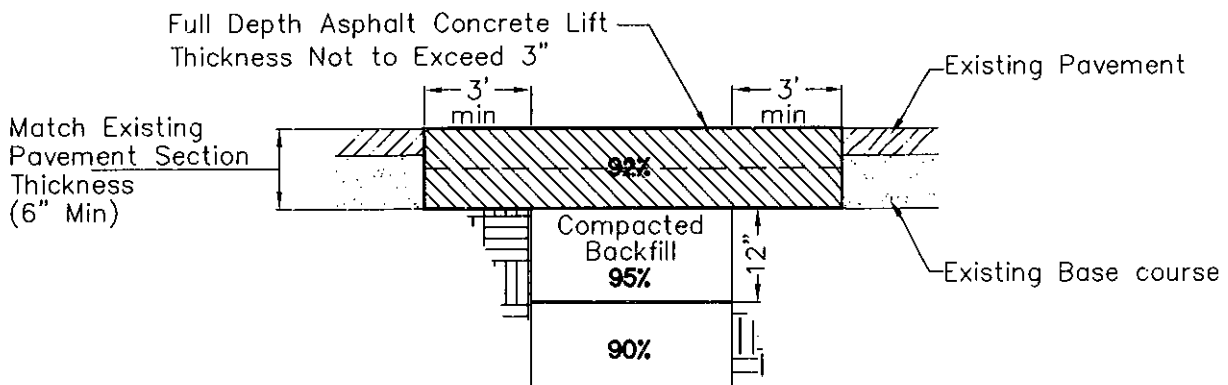

Type 'C' Repair

REVISION	APPROVED	DATE	CITY OF COEUR d'ALENE STANDARD DRAWING	APPROVED BY:
			TRENCH CUT PAVEMENT REPAIR	<i>Chris Boohy</i> 6/20/18
				CITY ENGINEER, PE 10804 DATE:
				DWG NO. M-11