



Agenda for the Regular Meeting Dalton Gardens City Council

Thursday, September 2, 2021 @ 6:00 PM

Location: DALTON GARDENS CITY HALL, 6360 N 4th St., Dalton Gardens, ID

Meeting will be conducted via teleconference and in person.
Please click this link to join the webinar via computer/smartphone:

<https://us02web.zoom.us/j/88426882117?pwd=TXV4SHZYdnpOaillT1Bpc2F6YIRqUT09>

Phone Number: 1-669-900-6833 or 1-346-248-7799 or 1-253-215-8782
Webinar ID: 884 2688 2117; Passcode: 667324

1. CALL TO ORDER:

2. ROLL CALL OF CITY COUNCIL MEMBERS:

3. PLEDGE OF ALLIGANCE:

4. PUBLIC COMMENT PERIOD:

Each speaker will be allowed a maximum of three (3) minutes to address the City Council on matters that relate to City government business. Comments related to future public hearings should be held forthat public hearing. Please be advised that the City Council can only take official action this eveningfor those items already listed on the agenda.

5. CONSENT CALENDAR- ACTION

a. Minutes from the:

- Regular Meeting August 5, 2021,
- Workshop August 10, 2021

b. Claims Listed from August 1, 2021 to August 30, 2021

c. Monthly Financial Statements:

- August 1-30, 2021

6. CITY REPORTS

- a. Council
- b. Mayor
- c. Planner
- d. Engineer
- e. City Attorney
- f. Clerk/Treasurer

7. NEW BUSINESS

- a. Consideration of proposed Ordinance 271 amending title 1 chapter 4, and title 8, chapters 1 and 2 of Dalton Gardens city code to provide for infraction penalties where applicable and adopt state infraction penalties.- **ACTION**
- b. Consideration of FY 21 budget line-item overage expenses for 401-012 Capital Outlay and 403-14 Street Maintenance Contracted- **ACTION**
- c. Consideration of direction to Treasurer appropriating \$30,000 of contingency fund in FY21 General Fund- **ACTION**
- d. Consideration of Resolution 2021-06 to establish carryover funds from FY21 to FY22- **ACTION**
- e. A public hearing, pursuant to Idaho Code 50-1002 and 63-802, held for consideration of the proposed budget for the fiscal year from October 1, 2021 to September 30, 2022, which includes \$1694.00 of forgone property taxes in the General Fund intended to fund additional road maintenance expenses in the city.- **ACTION**
- f. Consideration of Annual Appropriation Ordinance 270- **ACTION**
- g. Consideration of Resolution 2021-05 declaring the intent to collect \$1,694.00 in forgone property taxes for fiscal year 2022- **ACTION**
- h. Consideration to direct Treasurer to move \$200,000.00 in street funds into FY22 general fund for additional road maintenance and \$146,00 in LGIP funds into FY22 general fund for law enforcement- **ACTION**
- i. Discussion of agenda items for September 14, 2021 and October 7, 2021 Council Meetings.

8. ADJOURNMENT-**ACTION**

Original Posted 8/26/21

The purpose of this Agenda is to assist the Council and interested citizens in the conduct of the public meeting. Careful review of the Agenda is encouraged. Testimony from the public will be solicited for any item or issue listed under the category of Public Hearings. Any individual who wishes to address the Council on any other subject should plan to speak when Item: Public Comments is identified by the Mayor. The Mayor and Council will not normally allow audience participation at any other time. Please no repetitive or abusive comments. Workshops are for Council Members discussion only on a topic, no action or decisions occur at that time. No Public Comment is taken during Workshops. Assistance for persons with disabilities will be provided upon 24-hour notice prior to the meeting by calling the City Clerk at (208) 772-3698 ext 102.

City of Dalton Gardens
Regular Council Meeting Minutes
Thursday, August 5, 2021 @ 6:00pm

Meeting was conducted via teleconference and in person.

1. **CALL MEETING TO ORDER:** Mayor Edwards called the meeting to order at 6:07pm
2. **ROLL CALL:** Councilmembers Carrie Chase, Robert Wuest, Ray Craft and Mayor Dan Edwards were physically present. Councilmember Aaron O'Brien attended via Zoom. Chris Gabbert- City Attorney, and Teresa Janzen-City Clerk/Treasurer were also in attendance.
3. **PLEDGE OF ALLEGIENCE:** Deputy Clerk, Lyndsee Lee.
4. No Amendments to the Agenda
5. **PUBLIC COMMENTS:**
 - a. **Justin Wuest- 6808 N Mt. Carrol St:** Has applied for a fence permit but it is being held up as he desires a 6' fence on the property line and that is a violation of the current City Code. Requests code be modified for internal property lines to allow 6' fence.
 - b. **Clark Young- 7064 N 16th St:** Opposes small cell towers for health reasons and would like to see fines if emissions are too high.
 - c. **Kurt Jernigan- 7439 N Davenport St:** Disappointed that the City took ARPA funds as he feels it was not warranted and diminishes self-reliance. Would also like periodic testing and fines for non-compliance. Concerned about radiation.
6. **CONSENT CALENDAR**
 - a. RCraft made a motion to approve the regular meeting minutes from July 1, 2021. RWuest seconded.
RCraft: yes AO'Brien: yes CChase: no RWuest: yes Motion carries.
 - b. AO'Brien made a motion to approve the budget workshop and regular meeting minutes from July 15, 2021. RCraft seconded.
RCraft: yes AO'Brien: yes CChase: no RWuest: yes Motion carries.
 - c. AO'Brien made a motion to approve the budget workshop minutes from July 30, 2021. RWuest seconded.
RCraft: yes AO'Brien: yes CChase: no RWuest: yes Motion carries.
 - d. RWuest made a motion to approve the claims listed from July 16, 2021 to July 31, 2021. AO'Brien seconded.
RCraft: yes AO'Brien: yes CChase: yes RWuest: yes Motion carries.
 - e. RWuest made a motion to approve the monthly financial statements for June 1-30, 2021 and July 1-31, 2021. RCraft seconded.
RCraft: yes AO'Brien: yes CChase: yes RWuest: yes Motion carries.
 - f. CChase made a motion to approve the 3rd Quarter Treasurer's Finance Report. RCraft seconded.
RCraft: yes AO'Brien: yes CChase: yes RWuest: yes Motion carries.
7. **REPORTS**
 - a. **Councilmember Chase:** wants a proof of concept from the Sherriff on 25 tickets/day

- c. AO'Brien made motion to approve Anderson Brothers Contract for 2021 As-Needed Accounting Services Engagement Letter and 2021 Audit Prep Engagement Letter with the stipulation that it is reviewed every year. RWuest seconded.
RCraft: yes AO'Brien: yes CChase: yes RWuest: yes Motion carries.
- d. CChase made a motion to table request for P&Z to consider updating 5-5-4-C in order for them to focus on small cell ordinance. RCraft seconded.
RCraft: yes AO'Brien: no CChase: yes RWuest: yes Motion carries.
- e. Council set a workshop to consider the code amendments to various sections of Title 5 as indicated in the "Planning Commission Recommended Draft, June 11, 2020" for Tuesday, August 10, 2021 at 6:00 PM at City Hall.
- f. RWuest made a motion to approve the Stripe Rite Bid for striping of bike lanes and double yellow lines on 4th Street between Dalton Ave & Prairie; Dalton Ave from 4th Street to 17th Street; Canfield Ave from Government Way to Rude in the amount of \$4,805.90. CChase seconded.
RCraft: yes AO'Brien: yes CChase: yes RWuest: yes Motion carries.
- g. CChase made a motion to move the ARPA 1st Tranch of \$ 259,190.79 from main checking to the LGIP. RWuest seconded.
RCraft: yes AO'Brien: no CChase: yes RWuest: yes Motion carries.
- h. RWuest made a motion to approve tentative budget for FY22. AO'Brien seconded.
RCraft: yes AO'Brien: yes CChase: yes RWuest: yes Motion carries.
- i. Propose to have an item at the end of the agenda to discuss and consent for the next month's agenda items.
RWuest made a motion to table procedure for Council and Staff to place items on agenda.
RCraft: yes AO'Brien: yes CChase: no RWuest: yes Motion carries.

9. PUBLIC COMMENT

- a. Lezlie Laviola- 15227 Woodland Ave: requested list of HMM suggested locations for ROW furniture. Believed the Sheriff was supposed to start this fiscal year and frustrated that it hasn't happened. ARPA funds should be used for low-income residents benefits.

10. RWuest made a motion to Adjourn. RCraft seconded. All in favor. Meeting adjourned.

Dan Edwards, Mayor

ATTEST:

Teresa Janzen, City Clerk/ Treasurer

City of Dalton Gardens
Council Workshop Meeting Minutes
Tuesday, August 10, 2021 @ 6:00pm

Meeting was conducted via teleconference and in person.

1. **CALL MEETING TO ORDER:** Mayor Edwards called the meeting to order at 6:03 PM
2. **ROLL CALL:** Councilmembers Carrie Chase, Robert Wuest, Ray Craft, and Mayor Dan Edwards were physically present; Councilmember Aaron O'Brien attended via Zoom. Ryan Hughes- City Planner, Mike Becker- P&Z Chairman, and Teresa Janzen-City Clerk/Treasurer were also in attendance.
3. **CODE AMENDMENTS TO VARIOUS SECTIONS OF TITLE 5 AS INDICATED IN THE "PLANNING COMMISSION RECOMMENDED DRAFT, JUNE 11, 2020:**
 - a. Ryan Hughes gave an overview of the clean up of the sections indicated for clarity and housekeeping as well as to clean up code section conflicts.
 - b. Council discussed several items in the proposed amendment changes including
 - i. keeping a 5' setback for accessory structures as found in 5-5-4
 - ii. changing lot coverage to be a simple 40% of present parcel size and removing the 30,000 square feet or whichever is less verbiage.
 - iii. Removing 5-5-4-E for Building separation
 - iv. Removing the directive for fencing permits under 5-5-7
 - v. Removing 0.1 footcandle measurement for light trespass in 5-5-10
 - vi. Council directed City Planner to make suggested changes and prepare for a public hearing on Tuesday, September 14, 2021 at 6:00 PM.
4. Mayor discussed annual picnic historically being a 'thank you' to the citizens from the Council. Councilmember O'Brien made it known in February 2021 that he was not available as the date was chosen without his input. No other Councilmember wanted to Chair the Picnic so the picnic is cancelled for 2021.
5. **Mayor Edwards adjourned the workshop at 8:38 PM.**

Dan Edwards, Mayor

ATTEST:

Teresa Janzen, City Clerk/ Treasurer

To: Mayor Edwards, City of Dalton Gardens

From: HMH Engineering

Date: September 2, 2021

Re: Engineering update

1. Transportation Plan – HMH is continuing work on the Transportation Plan. The sign condition inventory was completed. The second transportation plan workshop was held on August 24, 2021. We received a large number of responses from the mailer that was sent out this past month.
2. 2021 Chip Seal Project – Contract requires chip sealing be completed prior to September 1st unless approved in writing. The Contract also requires the roadway surface to be 85 degrees Fahrenheit and rising. It does not appear that the weather conditions in September will meet these criteria. I have discussed this with RPI, Inc. Denise Lawless and Josh Polello and they are agreeable to mutually terminating the agreement.

The roadways from the 2021 chip seal project should be included into next years proposed project thereby increasing the size of the 2022 project.

3. 6039 N. 18th fire turnaround- Inspection performed on sign installation. Work **DOES NOT** meet requirements of engineered drawings. Inspection report included.
4. Utility Right-of-Way Encroachment Permits – All Active permits are shown on the attached table.

Project Name: City of Dalton Gardens Easement Date/Day: 8/17/2021
 Project Address: 6039 N. 18th St. Dalton Gardens Project No.: M20004 City of Dalton Gardens
 Client: City of Dalton Gardens Permit No.: _____

NOTES: HMH inspected sign installation at request of City. Public turnaround has been removed and graded with topsoil. Public turnaround sign has been installed but does not meet the requirements of the approved drawings. No parking Fire Lane sign has not been installed.

- Public Turnaround sign not constructed per approved drawings. Sheet Aluminum required.
- Brace angles not installed. Brace angles are required to prevent sign from bending in high wind or snow plowing. Follow punching schedule in approved drawings.
- Post not correct size and no breakaway holes drilled.
- Sign not mounted at correct height.
- No Parking/ Fire Lane sign not installed.

NOT APPROVED



EXISTING TURNAROUND REGRADED



INCORRECT SIGN HEIGHT / MISSING NO PARKING SIGN



NO BRACE ANGLES / INCORRECT POST SIZE

Project Representative: _____ Name/Company _____ HMH Representative: Matt Hall Name _____

PM: _____ All reports are considered preliminary until final review is complete. Reviewed: _____



PLAN

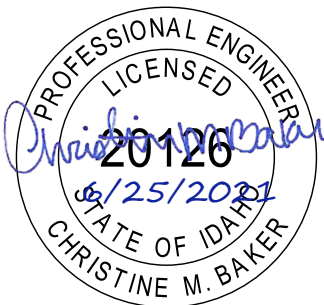

FIRE ACCESS ROAD
 6039 N. 18TH STREET
 DALTON GARDENS, IDAHO



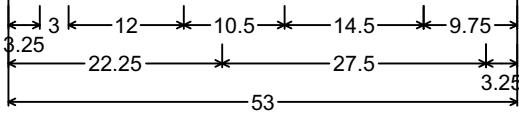
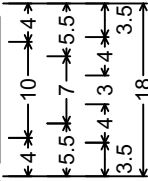

1.500" Radius, 0.500" Border, White on Green;
 Standard Arrow Custom 12.000" X 7.000" 0°;
 [Public] D 2K; [Turnaround] D 2K;
 Table of widths and spaces.

3.250	3.000	0.000	12.000
-------	-------	-------	--------

10.500	P 2.750	0.500	u 2.375	0.750	b 2.375	0.625	l 0.625	0.875	i 0.625	0.625	c 2.375	9.750
--------	---------	-------	---------	-------	---------	-------	---------	-------	---------	-------	---------	-------

22.250	T 2.500	0.500	u 2.375	0.750	r 1.500	0.500	n 2.375	0.500	a 2.375	0.750	r 1.500	0.250	o 2.500	0.625	u 2.375	0.750	n 2.375	0.625	d 2.375	3.250
--------	---------	-------	---------	-------	---------	-------	---------	-------	---------	-------	---------	-------	---------	-------	---------	-------	---------	-------	---------	-------

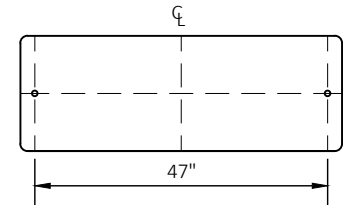

PUNCHING SCHEDULE
N.T.S.

NOTES:

- SIGN IS TO BE 0.080 INCH MINIMUM THICKNESS SHEET ALUMINUM WITH TYPE IX (MINIMUM) RETROREFLECTIVE SHEETING BACKGROUND AND A DIGITALLY PRINTED, SILK SCREENED INK, OR DIRECT APPLIED NONREFLECTIVE SHEETING LEGEND AND BORDER.

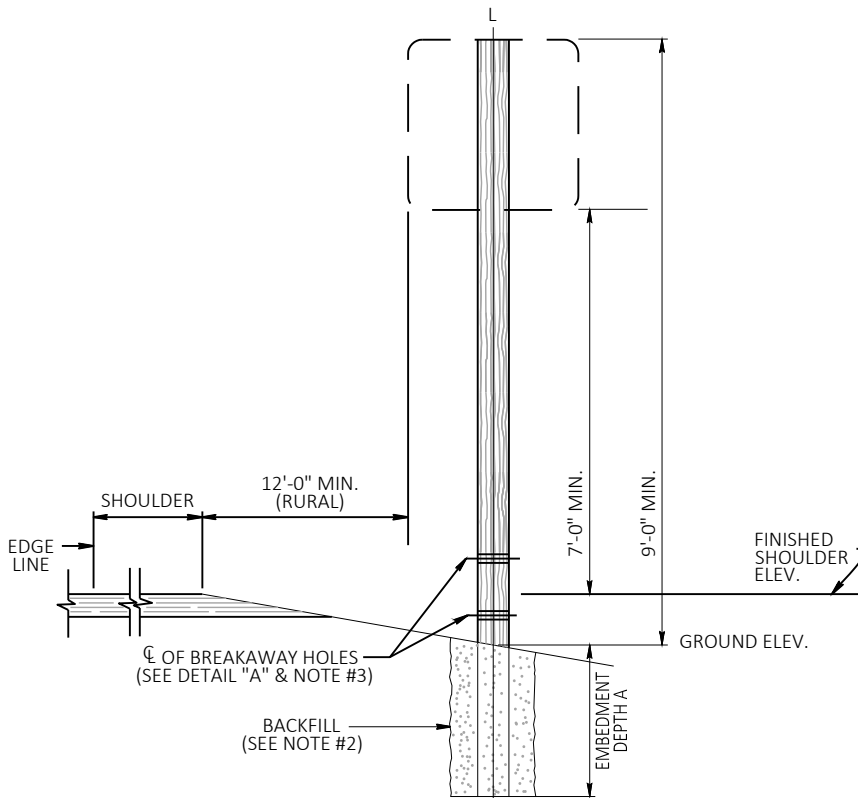

INSTALLATION DETAIL
N.T.S.

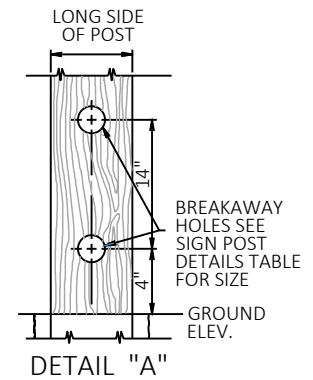

SIGN POST DETAILS TABLE

POST SIZE	EMBEDMENT DEPTH A	NOTCH DEPTH	BREAKAWAY HOLE SIZE
4"x6"	4'-0"	13/4"	1 1/2" DIA.

NOTES:

- PLACE LONG DIMENSION OF POST CROSS SECTION PERPENDICULAR TO THE SIGN FACE.
- BACKFILL SHALL BE APPROVED GRANULAR BORROW.
- BREAKAWAY HOLES SHALL BE FIELD DRILLED. POSTS 4"x6" AND LARGER REQUIRE BREAKAWAY HOLES. THE BREAKAWAY HOLES SHALL BE DRILLED PARALLEL TO THE SIGN FACE.
- POSTS SHALL BE PRESSURE TREATED.

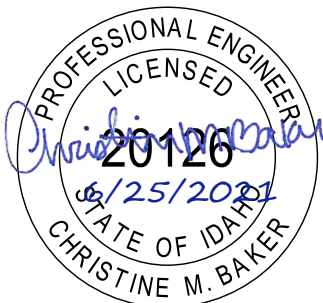

FIRE ACCESS ROAD
 6039 N. 18TH STREET
 DALTON GARDENS, IDAHO



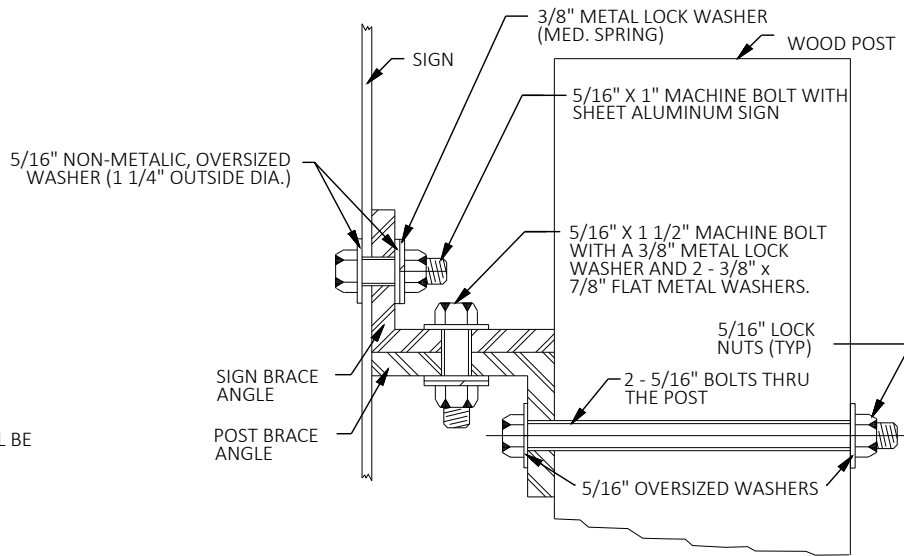

NOTES:

1. ALL BRACE ANGLES SHALL BE 13/4" x 13/4" x 1/4".

BRACE ANGLE ATTACHMENT DETAIL

N.T.S

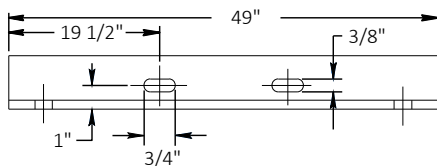

TYPICAL SLOT DETAIL
(SIGN BRACE ANGLE)

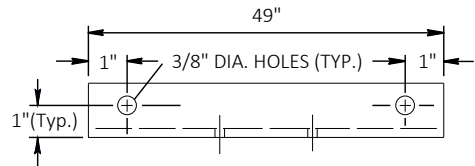

TYPICAL SIGN MOUNTING
HOLE DETAILS
(SIGN BRACE ANGLE)

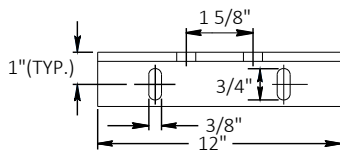

TYPICAL SLOT DETAIL
(POST BRACE ANGLE)

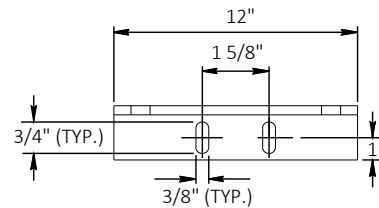

TYPICAL POST MOUNTING
SLOT DETAILS
(POST BRACE ANGLE)

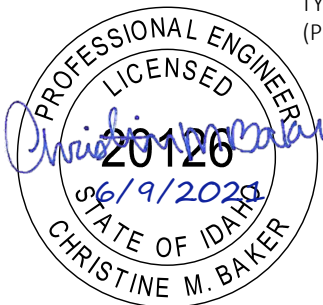

FIRE ACCESS ROAD
6039 N. 18TH STREET
DALTON GARDENS, IDAHO



3882 N. Schreiber Way, Suite 104
Coeur d'Alene, ID 83815
(208) 635-5825

Received for Review	Utility's Designated Permit ID	Application No.	Utility Company	Temp Permit Date	Final Permit Date	Location of Work	Construction Must Be Completed By:
10/27/2020	CDN03B_DA01_CO157	TDS 20-102720	TDS	10/27/2020		Near 6032 to 6167 N Valley	December 31, 2020
10/19/2020	CDN03A_DG_D02_03	ROW-2021-5	TDS	6/1/2021		Canfield and N 15th St	September 1, 2021
11/23/2020	CDN03A_DG_DA02_04	TDS 20-11232020	TDS	11/23/2020		E Wilbur at N Davenport St	May 23, 2021
11/25/2020	CDN03A_DG_DA03_03	TDS 20-11252020	TDS	11/30/2021		Near E Wilbur Ave and N 15th St	May 30, 2021
11/25/2020	CDN03A_DG_DA09_01	TDS 20-11262020	TDS	12/15/2020		Prairie Ave S of N 4th	August 31, 2021
12/31/2020	CDN03A_DG_NODE	TDS 21-05212021	TDS	5/21/2021		Node location address is assigned as 6081 N 15th St.	
3/22/2021		ROW 21-10	AVISTA	4/5/2021		455 E Dalton Ave.	
3/25/2021	HYLKIDXX DH22_N1_H3004	ROW-2021-8	ZIPLY	6/15/2021		1163 E Wilbur Ave - 576 FDH Pad Mounted Cabinet	
4/5/2021		ROW 21-042321	AVISTA	4/23/2021		7400 N Colfax; Missile bore under Colfax	
5/21/2021	HYLKIDXX RTE3_5503731 F1	ZIPLY 21-05212021	ZIPLY	6/15/2021		6439 N Mt Carrol; pole m	
5/26/2021		ROW-2021-6	AVISTA	6/2/2021		1852 E Canfield Ave.	September 1, 2021
-		ROW 21-02	AVISTA	3/22/2021	3/16/2021	5928 N Colfax	
5/26/2021		ROW-2021-1	AVISTA	6/1/2021		5776 N Davenport St	September 1, 2021
5/26/2021		ROW-2021-2	AVISTA	6/1/2021		5928 N Colfax	September 1, 2021
6/1/2021	HYLKIDXX H4016_5501554_DH54 S1	ROW-2021-4	ZIPLY	7/13/2021		7890 N Government Way	September 15, 2021
6/1/2021		ROW-2021-3	Dalton Water	6/15/2021		5928 N Colfax	
6/9/2021		ROW-2021-7	AVISTA	6/23/2021		7037 & 7009 N 16th St	
7/6/2021	CDN03A_DG_DA02_TRANSPORT_CO542	ROW-2021-9	TDS	8/24/2021		E Dalton Ave to 15th and up to 6911 N 15th	November 30, 2021
7/6/2021		ROW-2021-10	AVISTA	7/20/2021		7815 N Valley St.	September 1, 2021
7/21/2021	CDN03A_DG_DA03_TRANSPORT_CO543	ROW-2021-11	TDS			Various Locations	
7/28/2021	HYLKIDXX_H33006_5503699_DH21N1	ROW-2021-12	ZIPLY	8/18/2021		1647 E Hanley Ave - Proposed Location of FDH 576 Pad Mounted Cabinet. Aerial over-lash to existing cable/strand, pull foc & mst tails through existing conduit. Proposed splitters, snowshoes, ground rods, hand-holes. Designed to accommodate 6 fiber strands per 1000' for future 5G to 371 living units.	November 1, 2021
			Needs to be reviewed by HMM				
			Waiting on Revision				
			Needs Final Inspection				



CONTRACT CITY REPORT

CITY OF DALTON

JULY 2021

SERVICE HOURS	MONTH	YTD
PATROL DIVISION		
Patrol Deputies (Including Sergeants)	127.0	1,417.5
District Deputies	5.0	160.0
Animal Control Section	0.0	26.5
Community Service Section	16.0	138.0
TOTAL PATROL DIVISION	148.0	1,742.0
DETECTIVE DIVISION	57.5	238.5
TOTAL SERVICE HOURS	205.5	1,980.5
TOTAL C.O.P.P.S HOURS	0.0	0.0
TOTAL SCLP HOURS	0.0	0.0

ACTIVITY

Law Enforcement Calls	96	631.0
Accidents	1	13.0
Traffic Citations	36	146.0
Total Reports	8	57.0
Arrests	0	7.0

Respectfully Submitted,
Robert B. Norris, Sheriff



ORDINANCE NO 271

AN ORDINANCE OF THE CITY OF DALTON GARDENS, A MUNICIPAL CORPORATION OF THE STATE OF IDAHO, AMENDING TITLE 1 CHAPTER 4, AND TITLE 8, CHAPTERS 1 AND 2 OF DALTON GARDENS CITY CODE TO PROVIDE FOR INFRACTION PENALTIES WHERE APPLICABLE AND ADOPT STATE INFRACTION PENALTIES; PROVIDING FOR SEVERABILITY; PROVIDING REPEAL OF CONFLICTING ORDINANCES; AND PROVIDING AN EFFECTIVE DATE.

BE IT ORDAINED by the Mayor and City Council of the city of Dalton Gardens, Kootenai County, Idaho, that Title 1, Administrative, Chapter 4 General Penalty, Section 1-4-1, General Penalty; Title 8, Motor Vehicles and Traffic, Chapter 1, Motor Vehicle Code, Section 8-1-2, Penalties; Chapter 2, General Traffic Provisions, Section 8-2-4C, Violation are hereby amended as follows:

Section 1. Dalton Gardens City Code Title 1, Chapter 4, Section 1-4-1 is hereby amended as follows:

1-4-1: GENERAL PENALTY:

Any person convicted of a violation of any section or provision of this code, where no other penalty is set forth, shall be punished as follows. Violations of this code may be considered a criminal misdemeanor or an infraction and are punishable with fines or imprisonment. The city may also take civil action to compel compliance or performance.

A. Punishment For Misdemeanor: Every offense declared to be a misdemeanor is punishable by imprisonment in a county jail not exceeding six (6) months, or by a fine not exceeding one thousand dollars (\$1,000.00), or by both. The city may also take civil action to compel compliance of requirements or performance and completion of, or maintenance of, improvements installed pursuant to this section.

B. Punishment For Infraction: Every offense declared to be an infraction unless another infraction penalty is specifically provided is punishable only by a penalty not exceeding one hundred dollars (\$100.00) and no imprisonment. The city may also take civil action to compel compliance of requirements or performance and completion of, or maintenance of, improvements installed pursuant to this section.

Section 2. Dalton Gardens City Code Title 8, Chapter 1, Section 8-1-2 is hereby amended as follows:

8-1-2: PENALTIES:

Any violation of any of the provisions of said Idaho Motor Vehicle Laws shall be punishable by a fine not to exceed three hundred dollars (\$300.00) or imprisonment not to exceed six (6) months or both such fine or imprisonment. A violation of any of the traffic provisions set out in this code shall be an infraction unless another penalty is provided by state law, and, upon being found to have violated a traffic provision of this code, shall be penalized as allowed by state law.

Section 3. Dalton Gardens City Code Title 8, Chapter 2, Section 8-2-4 is hereby amended as follows:

8-2-4: USE OF AIR COMPRESSION BRAKES PROHIBITED:

A. Definitions: For purposes of this section, the following definitions shall apply:

COMPRESSION BRAKE: Any engine brake, air compression brake or mechanical exhaust braking device designed to aid in the braking or deceleration of any vehicle that results in excessive, loud, unusual, or explosive noise from such vehicle.

DESIGNATED ROADWAY: Any public highway, as defined in Section 40-117, Idaho Code, within the City of Dalton Gardens city limits.

B. Prohibited: It shall be unlawful for the driver of any vehicle to use or operate or cause to be used or operated a vehicle compression brake within any designated roadway except under emergency circumstances where the use of a compression brake is necessary to prevent an accident or injury to persons or property. Emergency vehicles, street maintenance equipment, and City vehicles are exempt from the prohibitory provisions of this Section.

C. Violation: Any person who violates any provision of this Section shall be deemed guilty of an infraction punishable pursuant to Section 1-4-1 of this Code unless otherwise provided under state law.

Section 4. This ordinance is hereby declared to be severable. Should any portion of this ordinance be declared invalid by a court of competent jurisdiction, the remaining provisions shall continue in full force and effect and shall be read to carry out the purpose(s) of the ordinance before the declaration of partial invalidity.

Section 5. All provisions of the current Dalton Gardens Municipal Code, or ordinances of the city of Dalton Gardens, which conflict with the provisions of this ordinance are hereby repealed to the extent of such conflict.

Section 6. This Ordinance shall be in full force and effect from and after its passage, approval, and publication according to law.

PASSED by the City Council as an Ordinance of the city of Dalton Gardens upon roll call vote on the ____ day of September, 2021.

APPROVED by the Mayor on this ____ day of September, 2021.

CITY OF DALTON GARDENS, IDAHO

By: _____
Dan Edwards, Mayor

ATTEST:

Teresa Janzen, City Clerk

RESOLUTION NO. 2021-06
CITY OF DALTON GARDENS
Transfer \$xxx,xxx from General Funds FY2021
to
General Funds FY2022 as Carryover

A **RESOLUTION** of the City Council of the City of Dalton Gardens, authorizing the commitment of Carryover funds of \$xxx,000 in Street Maintenance/Improvements, from the General Fund; as of the end of the 2021 Fiscal Year.

WHEREAS: The City of Dalton Gardens intends to manage Street Improvements as such management being necessary to meet the needs of the area for the health, safety, and wellbeing of the people; and

WHEREAS: The plan is to move a \$xxx,000 from FY2021 General Fund under Street Maintenance-Contracted line item into Street Maintenance-Contracted, of the General Fund for the 2022 fiscal budget year; and

WHEREAS: The designation of these funds will be as carryover fund balances into Street Maintenance-Contracted; under the General fund FY2022.

NOW, THEREFORE, BE IT RESOLVED by the City Council of the City of Dalton Gardens, Idaho, as follows:

- 1) The City of Dalton Gardens shall complete a one-time carryover designation into FY2022 Street Maintenance-Contracted from the same in the General Fund from FY2021.

APPROVED AND ADOPTED as a Resolution of the City of Dalton Gardens, Idaho, by the City Council in regular session on the 2nd day of September 2021, by the following vote:

AYES:

NOES:

ABSTAIN:

Mayor, Dan Edwards

ATTEST: _____
City Clerk/Treasurer Teresa Janzen

**CITY OF DALTON GARDENS
DRAFT FY22 BUDGET**

	Actuals		Actuals		Actuals thru 7/31/21		Budget FY22	Notes
	Oct '18 - Sep 19	Budget FY19	Oct '19 - Sep 20	Budget FY20	Oct '20 - Sep 21	Budget FY21		
Income								
MMCO 3	769,813.00		0.00		0.00			
301-000 · COMMUNITY DEV. INCOME								
301-02 · ADDITIONAL PLANNING CONS FEES	0.00		5,000.00		0.00			
301-03 · BUILDING PERMIT REVENUE								
301-034 · SIGN PERMIT FEES	0.00	300.00	430.70	300.00	0.00	0.00	300.00	
301-03 · BUILDING PERMIT REVENUE - Other	77,373.50	65,000.00	91,854.57	65,000.00	79,573.21	65,000.00	65,000.00	
Total 301-03 · BUILDING PERMIT REVENUE	77,373.50	65,300.00	92,285.27	65,300.00	79,573.21	65,000.00	65,300.00	
301-04 · BUSINESS LICENSE REVENUE								
301-041 · HOME BASED BUS LICENSE	325.00	300.00	250.00	300.00	275.00	300.00	250.00	
301-04 · BUSINESS LICENSE REVENUE - Other	7,450.00	7,000.00	6,700.00	7,000.00	4,850.00	7,500.00	7,500.00	
Total 301-04 · BUSINESS LICENSE REVENUE	7,775.00	7,300.00	6,950.00	7,300.00	5,125.00	7,800.00	7,750.00	
301-05 · FACILITY RESERVATION REVENUE	0.00		0.00		100.00		500.00	
301-06 · FINES	0.00		0.00		60.00			
301-07 · SPECIAL USE FEES	1,575.00	1,000.00	3,010.00	1,000.00	1,330.00	1,000.00	1,000.00	
301-08 · SUBDIVISION REVENUE	0.00		0.00		1,000.00		1,000.00	
Total 301-000 · COMMUNITY DEV. INCOME	86,723.50	73,600.00	107,245.27	73,600.00	87,188.21	73,800.00	75,550.00	
302-000 · FRANCHISE FEES								
302-01 · FRANCHISE FEE AVISTA	25,912.66	25,000.00	26,556.61	26,000.00	26,765.80	25,000.00	26,000.00	
302-02 · FRANCHISE FEE TWC/SPECTRUM	23,745.38	22,000.00	26,637.74	22,000.00	18,265.67	22,000.00	26,000.00	
302-03 · FRANCHISE FEE TDS	0.00		0.00		77.68		1,000.00	
Total 302-000 · FRANCHISE FEES	49,658.04	47,000.00	53,194.35	48,000.00	45,109.15	47,000.00	53,000.00	
303-000 · HIGHWAY FUNDS								
303-01 · HIGHWAY USERS REVENUE	88,882.93	85,900.00	85,651.47	85,000.00	116,530.63	71,497.00	87,069.00	
303-02 · NEW HIGHWAY USER REVENUE	27,318.23	26,900.00	26,686.72	26,800.00	28,217.48	22,144.00	29,604.00	
303-03 · TRANSFER HWY DISTRICT LEVY	58,802.47	48,000.00	61,219.54	48,000.00	61,691.91	40,000.00	40,000.00	
Total 303-000 · HIGHWAY FUNDS	175,003.63	160,800.00	173,557.73	159,800.00	206,440.02	133,641.00	156,673.00	
304-000 · LID ASSESSMENTS								
304-01 · LID # 1 Assessments								
304-011 · LID#1 Assessments Interest	5,890.76		6,329.68	0.00	0.00	0.00	0.00	
304-01 · LID # 1 Assessments - Other	16,830.71	34,000.00	28,531.26	25,000.00	19,806.55	35,000.00	21,873.58	
Total 304-01 · LID # 1 Assessments	22,721.47	34,000.00	34,860.94	25,000.00	19,806.55	35,000.00	21,873.58	
304-02 · LID #2 - GOVERNMENT WAY								
304-021 · LID #2 Assessment Interest	29.00		20,506.00		23,462.87			
304-02 · LID #2 - GOVERNMENT WAY - Other	288,072.95	1,025,724.00	211,837.35	65,213.00	68,484.23	65,213.00	43,903.15	
Total 304-02 · LID #2 - GOVERNMENT WAY	288,101.95	1,025,724.00	232,343.35	65,213.00	91,947.10	65,213.00	43,903.15	
304-03 · LID Interest Income	297.64		484.40		0.00			
Total 304-000 · LID ASSESSMENTS	311,121.06	1,059,724.00	267,688.69	90,213.00	111,753.65	100,213.00	65,776.73	
305-000 · PROPERTY TAXES								
305-01 · AG EQUIP REPLACEMENT	0.00		0.00		0.50			
305-02 · CURRENT REAL PROPERTY TAX	152,101.24	148,900.00	157,802.07	153,367.00	166,618.85	160,589.00	168,919.00	168919 includes 1694 from Forgone- decrease of 2171
305-03 · DELINQUENT REAL PROPERTY TAX	1,970.09	1,500.00	1,549.21	1,500.00	1,405.67	1,411.00	1,500.00	
305-04 · PENALTY & INTEREST	577.45	500.00	547.26	500.00	385.07	500.00	500.00	
Total 305-000 · PROPERTY TAXES	154,648.78	150,900.00	159,898.54	155,367.00	168,410.09	162,500.00	170,919.00	
306-000 · STATE REVENUE SHARE								
306-01 · STATE LIQUOR ALLOCATION	95,969.00	85,000.00	103,315.00	91,000.00	82,032.00	88,000.00	102,540.00	
306-02 · STATE REVENUE SHARING	170,203.12	160,000.00	201,069.04	173,000.00	224,688.92	169,872.00		
306-03 · STATE SALES TAX	43,035.05	39,000.00	35,763.74	45,000.00	0.00	44,000.00	230,768.00	
Total 306-000 · STATE REVENUE SHARE	309,207.17	284,000.00	340,147.78	309,000.00	306,720.92	301,872.00	333,308.00	
307-000 · OTHER INCOME								
307-02 · COURT REVENUE-TRAFFIC FINES	10,048.24	10,000.00	5,047.78	10,000.00	4,880.39	5,000.00	5,000.00	
307-03 · INTEREST INCOME	50,624.63	21,000.00	31,063.96	34,000.00	5,287.80	5,000.00	5,000.00	

**CITY OF DALTON GARDENS
DRAFT FY22 BUDGET**

	Actuals		Actuals		Actuals thru 7/31/21		Budget FY22	Notes
	Oct '18 - Sep 19	Budget FY19	Oct '19 - Sep 20	Budget FY20	Oct '20 - Sep 21	Budget FY21		
307-05 · REFUNDS & REIMBURSEMENTS	8,159.59	0.00	1,668.01	0.00	629.97			
307-06 · RENT	5,040.00	5,000.00	5,946.20	5,000.00	5,200.00	6,240.00	6,240.00	
307-08 · UNENCUMBERED BANK FUNDS	0.00	130,688.00	0.00	37,795.00	0.00	329,201.50	346,000.00	200,000 from Street Funds+
307-09 · ARPA	0.00		0.00		259,190.79			146,000 from LGIP for Officer
307-10 · CARES ACT	0.00		0.00		77,023.44			
Total 307-000 · OTHER INCOME	73,872.46	166,688.00	43,725.95	86,795.00	352,212.39	345,441.50	362,240.00	
308-000 · GRANT FUNDS								
308-01 · 4th STREET PROJECT ITD GRANT	90,364.03	0.00	10,771.96	0.00	0.00			
308-03 · CONTRIBUTIONS & DONATIONS	1,000.00	2,000.00	0.22	1,000.00	0.00	1,000.00		
308-07 · SCHOLARSHIPS	0.00		0.00		335.00			
Total 308-000 · GRANT FUNDS	91,364.03	2,000.00	10,772.18	1,000.00	335.00	1,000.00		
Total Income	2,021,411.67	1,944,712.00	1,156,230.49	923,775.00	1,278,169.43	1,165,467.50	1,217,466.73	
Gross Profit	2,021,411.67	1,944,712.00	1,156,230.49	923,775.00	1,278,169.43	1,165,467.50	1,217,466.73	
Expense								
401-000 · GENERAL & ADMIN								
401-01 · CAPITAL OUTLAY								
401-012 · CAPITAL OUTLAY-EQUIPMENT	0.00		5,644.00	0.00	38,773.00	50,000.00	0.00	
Total 401-01 · CAPITAL OUTLAY	0.00		5,644.00	0.00	38,773.00	50,000.00	0.00	
401-03 · COUNCIL EXPENSES								
401-031 · CITY COUNCIL PAYROLL TAXES	1,384.28	1,475.00	1,468.80	1,475.00	1,346.40	1,500.00	1,500.00	
401-032 · CITY COUNCIL RETIREMENT	2,085.54	2,500.00	1,974.48	2,400.00	1,591.04	2,200.00	2,200.00	
401-033 · CITY COUNCIL SALARIES	18,095.30	19,200.00	19,200.00	19,200.00	17,600.00	19,200.00	19,200.00	
401-034 · MAYOR PAYROLL TAXES	659.42	781.00	780.31	781.00	715.28	780.00	780.00	
401-035 · MAYOR STATE RETIREMENT	1,001.75	1,250.00	1,229.44	1,325.00	1,116.39	1,325.00	1,325.00	
401-036 · MAYOR WAGES	8,619.76	10,200.00	10,200.00	10,200.00	9,350.00	10,200.00	10,200.00	
Total 401-03 · COUNCIL EXPENSES	31,846.05	35,406.00	34,853.03	35,381.00	31,719.11	35,205.00	35,205.00	
401-04 · OFFICE EXPENSES								
401-041 · BLDG MAINT CONTRACTED	3,398.00	4,000.00	3,034.63	3,000.00	459.00	3,000.00	3,000.00	
401-042 · BLDG & GROUNDS MAINTENANCE	3,412.52	4,000.00	3,731.00	4,000.00	3,367.77	5,000.00	5,000.00	
401-043 · DUES & SUBSCRIPTIONS	2,653.15	2,500.00	2,346.53	2,500.00	4,172.78	2,500.00	2,500.00	
401-045 · GARBAGE COLLECTION & DISPOSAL	407.81	500.00	511.38	500.00	385.00	500.00	500.00	
401-046 · OFFICE MAINTENANCE	613.30	600.00	585.28	600.00	635.25	600.00	600.00	
401-047 · OFFICE SUPPLIES & POSTAGE	4,915.44	5,000.00	7,622.88	8,000.00	4,879.42	8,000.00	8,000.00	
401-048 · SOFTWARE PURCHASE & IT SERVICE	6,658.87	5,000.00	9,361.32	20,000.00	5,473.48	20,000.00	20,000.00	
Total 401-04 · OFFICE EXPENSES	22,059.09	21,600.00	27,193.02	38,600.00	19,372.70	39,600.00	39,600.00	
401-05 · PERSONNEL EXPENSE								
401-050 · COMPANY PAYROLL TAX EXPENSE	-0.60		0.01					
401-051 · CLERK PAYROLL TAXES	3,902.80	3,902.81	4,000.40	4,001.00	3,655.47	4,120.85	4,004.00	
401-052 · CLERK RETIREMENT	5,854.20	5,992.00	6,243.84	6,250.00	5,775.23	6,431.15	6,240.00	
401-053 · CLERK UI TAXES	163.63	274.00	107.27	250.00	76.60	138.00	156.00	
401-054 · CLERK WAGES	51,017.04	51,017.06	52,423.75	52,293.00	53,124.81	53,862.00	52,000.00	
401-055 · DEPUTY CLERK-PAYROLL TAXES	1,313.48	1,656.28	1,284.31	1,377.00	1,112.92	1,418.31	2,926.00	
401-056 · DEPUTY CLERK RETIREMENT	1,450.49	2,605.13	1,993.22	2,150.00	1,654.44	2,213.69	4,560.00	
401-057 · DEPT CLERK-UI TAXES	60.22	120.00	50.64	76.00	40.12	60.00	152.00	
401-058 · DEPUTY CLERK WAGES	17,169.60	21,650.72	17,111.64	18,000.00	14,547.91	18,540.00	38,000.00	1900 hours/FY
401-059 · EMP HEALTH INSURANCE	23,195.86	34,500.00	13,568.00	24,000.00	13,770.00	24,000.00	26,400.00	
Total 401-05 · PERSONNEL EXPENSE	104,126.72	121,718.00	96,783.08	108,397.00	93,757.50	110,784.00	134,438.00	
401-06 · PROFESSIONAL SERVICES								
401-061 · AUDIT AND ACCOUNTING	7,498.75	7,500.00	9,195.00	12,000.00	10,173.25	12,000.00	24,000.00	includes Forensic audit \$12K
401-062 · LEGAL PUBLISHING	3,285.97	4,000.00	1,740.74	4,000.00	770.13	4,000.00	4,000.00	
401-063 · ATTORNEY RETAINER	9,588.59	35,873.00	0.00		0.00			

**CITY OF DALTON GARDENS
DRAFT FY22 BUDGET**

	Actuals		Actuals		Actuals thru 7/31/21		Budget FY22	Notes
	Oct '18 - Sep 19	Budget FY19	Oct '19 - Sep 20	Budget FY20	Oct '20 - Sep 21	Budget FY21		
401-06 · PROFESSIONAL SERVICES - Other	101,078.33	30,000.00	134,117.00	72,000.00	55,251.00	80,000.00	64,000.00	
Total 401-06 · PROFESSIONAL SERVICES	121,451.64	77,373.00	145,052.74	88,000.00	66,194.38	96,000.00	92,000.00	
401-07 · UTILITES								
401-071 · BLDG & GROUNDS UTILITIES	5,455.09	6,500.00	7,183.21	6,000.00	6,971.00	8,000.00	8,000.00	
401-073 · TELEPHONE	2,039.52	2,200.00	1,999.60	2,000.00	2,111.80	2,800.00	2,800.00	
Total 401-07 · UTILITES	7,494.61	8,700.00	9,182.81	8,000.00	9,082.80	10,800.00	10,800.00	
401-08 · ANNUAL PICNIC	2,999.33	5,500.00	0.00	3,500.00	0.00	3,500.00	3,500.00	
401-11 · GENERAL CONTINGENCY FUND	0.00	30,000.00	0.00	30,000.00	0.00	30,000.00	31,231.00	decreased by 2171 for income acct 305-02 change
401-12 · INSURANCE	5,839.50	7,500.00	5,766.00	7,500.00	6,574.00	7,500.00	7,500.00	
401-13 · MISCELLANEOUS SERVICE & CHARGES	1,776.81	1,500.00	1,778.51	1,800.00	63.06	1,800.00	1,800.00	
401-15 · UNCATEGORIZED EXPENSES	0.00		0.00		77,023.44		725.73	
401-16 · TRAINING AND TRAVEL Expenses	0.00		0.00				3,200.00	
411-047 · CITY COUNCIL TRAVEL/MEETINGS	39.00	1,000.00	156.00	1,000.00	160.00	1,000.00		
413-047 · MAYOR TRAVEL & MEETINGS	39.00	500.00	39.00	500.00	0.00	500.00		
415-047 · CLERK TRAVEL @ MEETINGS	1,185.11	1,500.00	306.50	1,500.00	1,065.76	1,500.00		
416-021 · ATTORNEY PAYROLL TAXES	994.30	2,745.00	0.00		0.00			
416-022 · ATTORNEY STATE RETIREMENT	1,471.31	4,200.00	0.00		0.00			
416-047 · ATTORNEY TRAVEL & MEETINGS	0.00	100.00	0.00		0.00			
Total 401-000 · GENERAL & ADMIN	301,322.47	319,342.00	326,754.69	324,178.00	343,785.75	388,189.00	359,999.73	
402-000 · LAW ENFORCEMENT								
402-01 · CODE ENFORCEMENT-CLEAN UP	0.00	0.00	0.00		0.00			
402-02 · CODE ENFORCEMENT-PAYROLL TAXES	0.00		126.22	0.00	294.72	1,147.50		
402-03 · CODE ENFORCMENT- RETIREMENT	0.00		504.02	0.00	460.00	1,791.00		
402-04 · CODE ENFORCEMENT-UI TAX	0.00		7.52	0.00	8.80	40.00		
402-05 · CODE ENFORCEMENT-WAGES	15,580.00	25,000.00	6,885.00	20,000.00	3,172.50	15,000.00	12,000.00	Contractor
402-06 · PROSECUTING ATTORNEY	1,450.00	2,500.00	2,030.00	2,000.00	1,740.00	1,740.00	1,740.00	
402-08 · SPECIAL LAW ENFORCEMENT EXP	12,879.39	15,000.00	7,067.63	12,000.00	0.00	0.00	146,000.00	LGIP Funds for Officer Exp
Total 402-000 · LAW ENFORCEMENT	29,909.39	42,500.00	16,620.39	34,000.00	5,676.02	19,718.50	159,740.00	
403-000 · STREETS								
403-01 · 4th STREET PROJECT	97,925.16	110,000.00	14,169.14	75,000.00	0.00			
403-04 · DEBT SERVICE	16,000.00		18,000.00		0.00			
403-05 · FIRE HYDRANTS	0.00	5,000.00	0.00	0.00	0.00	0.00		
403-06 · FUEL AND LUBRICANTS	1,462.13	2,000.00	1,209.62	1,600.00	858.94	2,000.00	2,000.00	
403-10 · ROADS-ENG PLANS & SERVICES	22,566.60	20,000.00	13,512.58	25,000.00	24,220.13	50,000.00	37,000.00	Boundary Survey
403-11 · SNOW & ICE CONTROL-REMOVAL	6,789.85	27,000.00	3,416.34	28,000.00	2,282.63	30,000.00	30,000.00	
403-12 · STREET EQUIPMENT MAINTENANCE	4,795.70	9,000.00	4,338.44	7,000.00	784.68	7,000.00	7,000.00	
403-13 · STREET MAINT- PAYROLL TAXES	659.24	630.00	1,750.30	630.00	800.39	2,000.00	2,000.00	
403-14 · STREET MAINT- CONTRACTED	176,920.35	175,000.00	435,655.94	415,000.00	22,513.50	399,000.00	358,367.00	200,000 FROM ST FUND + 1694 from Forgone
403-15 · STREET MAINT- RETIREMENT	0.00		237.78		0.00			
403-16 · STREET MAINT-SUPPLIES	0.00		0.00		1,397.76		1,000.00	
403-17 · STREET MAINT- UI TAX	31.31	47.00	56.72	45.00	29.61	55.00	55.00	
403-18 · STREET MAINT - WAGES	8,909.00	8,230.00	18,254.25	8,200.00	11,138.17	25,000.00	25,000.00	
403-20 · STREET SIGNAL LIGHTS	458.26	500.00	449.20	500.00	350.63	500.00	500.00	
Total 403-000 · STREETS	336,517.60	357,407.00	511,050.31	560,975.00	64,376.44	515,555.00	462,922.00	
404-000 · PARKS								
404-01 · HORSE ARENA EXPENSES	7,463.27	9,000.00	871.42	9,000.00	1,806.28	9,000.00	9,000.00	
404-03 · PARK MAINTENANCE- CONTRACTED	19,008.77	35,000.00	16,890.66	35,000.00	12,565.44	35,000.00	30,000.00	
404-04 · PARK MAINTENANCE- PAYROLL TAX	343.63	570.00	137.16	475.00	425.82	475.00	475.00	
404-05 · PARK MAINTENANCE- RETIREMENT	0.00	0.00	0.00		0.00			
404-06 · PARK MAINTENANCE- UI TAX	25.33	45.00	1.28	30.00	6.11	30.00	30.00	
404-07 · PARK MAINTENANCE- WAGES	4,200.25	7,420.00	3,551.00	6,000.00	5,852.25	6,000.00	6,000.00	
404-08 · PUBLIC ART FUND EXPENSE	0.00	3,300.00	0.00	0.00	0.00			

**CITY OF DALTON GARDENS
DRAFT FY22 BUDGET**

	Actuals		Actuals		Actuals thru 7/31/21		Budget FY22	Notes
	Oct '18 - Sep 19	Budget FY19	Oct '19 - Sep 20	Budget FY20	Oct '20 - Sep 21	Budget FY21		
404-09 · SUPPLIES- PARK MAINT	391.83	2,000.00	489.89	1,500.00	487.06	1,500.00	1,500.00	
Total 404-000 · PARKS	31,433.08	57,335.00	21,941.41	52,005.00	21,142.96	52,005.00	47,005.00	
405-000 · LID								
405-01 · Gov't Way Sewer Project/LID #1								
405-011 · Loan Principal Payment - LID #1	27,827.44		28,814.93		0.00			
405-012 · Loan Interest Payment - LID #1	5,643.56		4,656.07		0.00			
405-01 · Gov't Way Sewer Project/LID #1 - Other	62.00	34,000.00	62.00	34,000.00	33,523.00	34,000.00	34,000.00	
Total 405-01 · Gov't Way Sewer Project/LID #1	33,533.00	34,000.00	33,533.00	34,000.00	33,523.00	34,000.00	34,000.00	
405-02 · LID PHASE 2								
405-021 · LID 2 Principal Payment	1,069,987.94		40,873.40		0.00			
405-022 · LID 2 Interest Expense	22,940.50		24,340.20		0.00			
405-02 · LID PHASE 2 - Other	58,230.15	1,025,724.00	62.00	65,213.00	65,235.60	65,500.00	65,500.00	
Total 405-02 · LID PHASE 2	1,151,158.59	1,025,724.00	65,275.60	65,213.00	65,235.60	65,500.00	65,500.00	
Total 405-000 · LID	1,184,691.59	1,059,724.00	98,808.60	99,213.00	98,758.60	99,500.00	99,500.00	
407-000 · COMMUNITY DEV.								
407-01 · PLANNING & ZONING								
407-011 · PLANNING CONSULTANT	42,379.00	50,000.00	51,665.50	50,000.00	36,450.56	50,000.00	25,000.00	
407-012 · PLANNING SOFTWARE							13,300.00	
417-043 · P & Z TRAVEL & MEETING EXP	262.23	500.00	0.00	500.00	0.00	500.00		
Total 407-01 · PLANNING & ZONING	42,641.23	50,500.00	51,665.50	50,500.00	36,450.56	50,500.00	38,300.00	
407-02 · BUILDING INSPECTOR SERVICES	35,326.00	55,000.00	41,884.00	40,000.00	45,201.77	40,000.00	50,000.00	
407-03 · KOOTENAI AREA TRANSPORTATION SY	2,904.00	2,904.00	2,904.00	2,904.00	0.00			
Total 407-000 · COMMUNITY DEV.	80,871.23	108,404.00	96,453.50	93,404.00	81,652.33	90,500.00	88,300.00	
Total Expense	1,964,745.36	1,944,712.00	1,071,628.90	1,163,775.00	615,392.10	1,165,467.50	1,217,466.73	
Net Income	56,666.31	0.00	84,601.59	-240,000.00	662,777.33	0.00	0.00	

**CITY OF DALTON GARDENS
APPROPRIATION ORDINANCE NO 270**

An Ordinance of the CITY OF DALTON GARDENS, IDAHO entitled the ANNUAL APPROPRIATION ORDINANCE for the fiscal year beginning October 1, 2021, and ending September 30, 2022, appropriating the sum of \$1,219,637.73 to defray the expenses and liabilities of the CITY OF DALTON GARDENS for said fiscal year, authorizing a levy of a sufficient tax upon the taxable property and specifying the objects and purposes for which said appropriation is made.

BE IT ORDAINED by the Mayor and Council of the City of Dalton Gardens, Kootenai County, Idaho:

Section 1: That the sum of \$1,219,637.73 is, and the same is appropriated to defray the necessary expenses and liabilities of the City of Dalton Gardens, Kootenai County, Idaho for the fiscal year beginning October 1, 2021.

Section 2: The objects and purposes for which such appropriation is made, and the amount of each object and purpose is as follows:

**ESTIMATED EXPENDITURES:
GENERAL FUND**

Administration	362,170.73
Law Enforcement	159,740.00
Parks	47,005.00
Planning & Zoning	<u>88,300.00</u>
TOTAL	657,215.73
Street Department	462,922.00
LID Sewer Project	<u>99,500.00</u>
	562,422.00
TOTAL EXPENDITURES	\$1,219,637.73

Section 3: That a general tax levy on all taxable property with the City of Dalton Gardens be levied in an amount allowed by law for the general purposes for said City, for the fiscal year beginning October 1, 2021.

Section 4: All ordinances and parts of ordinances in conflict with this ordinance are hereby repealed.

Section 5: This ordinance shall take effect and be in full force upon its passage, approval and publication in one issue of the Coeur d'Alene Press, a newspaper of general circulation in the City of Dalton Gardens, and the official newspaper of said City.

PASSED under suspension of rules upon which a roll call vote was taken and duly enacted an Ordinance of the City of Dalton Gardens, Kootenai County, Idaho at a convened meeting of the City of Dalton Gardens City Council held on the 2nd day of September 2021.

Dan Edwards, Mayor

Teresa Janzen, City Clerk/Treasurer

RESOLUTION NO 2021-05

CITY OF DALTON GARDENS

Transfer \$200,000 from Street Fund FY2021 to General Fund FY2022 for additional road maintenance

and

Transfer \$146,000 from LGIP Fund FY2021 to General Fund FY2022 for Law Enforcement

A RESOLUTION of the City Council of the City of Dalton Gardens, authorizing the commitment of street funds of \$200,000, from the Street Fund from Fiscal Year 2021 and \$146,000 of LGIP funds from Fiscal Year 2021/

WHEREAS: The City of Dalton Gardens intends to manage Street Improvements; and secure dedicated law enforcement; as being necessary to meet the needs of the area for the health, safety, and wellbeing of the people; and

WHEREAS: The plan is to move a \$200,000 from FY2021 Street Funds for additional road maintenance and \$146,00 from LGIP Funds for establishment of dedicated law enforcement into Unencumbered Funds, of the General Fund for the 2022 fiscal budget year.

NOW, THEREFORE, BE IT RESOLVED by the City Council of the City of Dalton Gardens, Idaho, as follows:

- 1) The City of Dalton Gardens shall complete a one-time movement of \$200,00 of Street Funds from FY2021 into FY2022 Unencumbered Funds in the General Fund.
- 2) The City of Dalton Gardens shall complete a one-time movement of \$146,000 of LGIP Funds into FY2022 Unencumbered Funds in the General Fund for the procurement of law enforcement.

APPROVED AND ADOPTED as a Resolution of the City of Dalton Gardens, Idaho, by the City Council in regular session on the 2nd day of September 2021, by the following vote:

Upon a motion made by Councilmember _____, seconded by Councilmember _____, the following vote was recorded:

Council Member Chase	_____ Yes	_____ No
Council Member Craft	_____ Yes	_____ No
Council Member O'Brien	_____ Yes	_____ No
Council Member Wuest	_____ Yes	_____ No

Upon said roll call, the City of Dalton Gardens hereby declares its intent to move \$200,000 in Street Funds from fiscal year 2021 into fiscal year 2022 general fund and declaring the purpose for which the Street Funds are being budgeted, and has duly enacted the same as a Resolution of the City of Dalton Gardens, Kootenai County, Idaho, on the 2nd day of September 2021.

APPROVED by the City Council on this 2nd day of September 2021.

CITY OF DALTON GARDENS

By: _____, Mayor

Dan Edwards

ATTEST:

_____, City Clerk
Teresa Janzen